

ALPINE ACV

AUTOMATIC WATER CONTROL VALVES



C o n t r o l V a l v e s

T O T A L V A L V E S O L U T I O N S

Ultra Control Valves cc was formed in 2009 in order to present a Company in the market place who's efforts are mostly concentrated on Automatic Control Valves and with an emphasis on the new Ultra Alpine ACV Automatic Water Control Valve product. This valve has its design origins in the USA (Claval) and has been copied by many companies worldwide because of its high level of technical advantages over competitive products. With a combined experience of over 70 years in the valve industry, the Personnel of Ultra are committed to offer superior service in both pre-sales (application advise and consulting) and after-sales (commissioning/trouble shooting). Although the concentration is on Control valves, a complete range of other valves are available – all aimed at providing long life and complete Pipeline solutions, including Waterhammer reduction techniques and products.

Introduction

Purchasing Automatic Control Valves is a critical balancing act. On the one hand you want a reliable product of unquestionable quality; on the other hand you want a product that is supported by a trusted after sales set-up. With the Ultra Alpine ACV valve, you can get both a quality product and unsurpassed product support from Ultra Control Valves. Our well-trained and experienced sales engineers offer specification assistance, analysing system conditions to recommend the right valve for your application. Ultra Control Valves does not sell valves, we sell control valve solutions. The after sales service supplied by Ultra Control Valves personnel has stood the test of time.

The Ultra Alpine ACV valve is made from ductile iron, with a fusion-bonded epoxy coating. You can now get a tough valve body, offering not only a long life, but also minimal maintenance under the harsh conditions experienced in various industries in Southern Africa. For tougher applications we offer our all stainless steel valve, which is an affordable and acceptable option for aggressive water of high and low ph values.

FBE coating

The role of a high quality coating on the valve body cannot be underestimated. The Ultra Alpine ACV valve is coated with a fusion bonded powder coating to a minimum thickness of 250 microns. RAL 5005 is one of the finest FBE coatings and is approved for drinking water by WRAS. The coating protects the valve from environmental attack externally, as well as rust and mineral build up (a major factor in control valve failure) internally. It prolongs the life of the valve and makes servicing very easy.

Efficient valve design

The Ultra Alpine ACV valve is a globe style, diaphragm actuated, hydraulic pilot operated control valve. The globe design has superior features, which make it the

best for the regulation of fluids. The spindle assembly, which carries the diaphragm and seat, is the only moving part in the valve. This simple design ensures a reliable and trouble-free valve life. The spindle assembly is supported at both ends by bearings, which stabilises throttling and assists positive closure with a near frictionless operation. This design has proven to be superior to Y-Pattern single bearing designs which suffer from early bearing wear and subsequent faulty operation – including seizure of the Diaphragm Assembly.

Seat Arrangement

The main Seal is a flat EPDM as with most other manufacturers. Seat contours are designed to guide the flow away from impinging directly onto the seal. The Stainless Steel seat is retained in the body in 3 different methods depending on the valve size as shown.

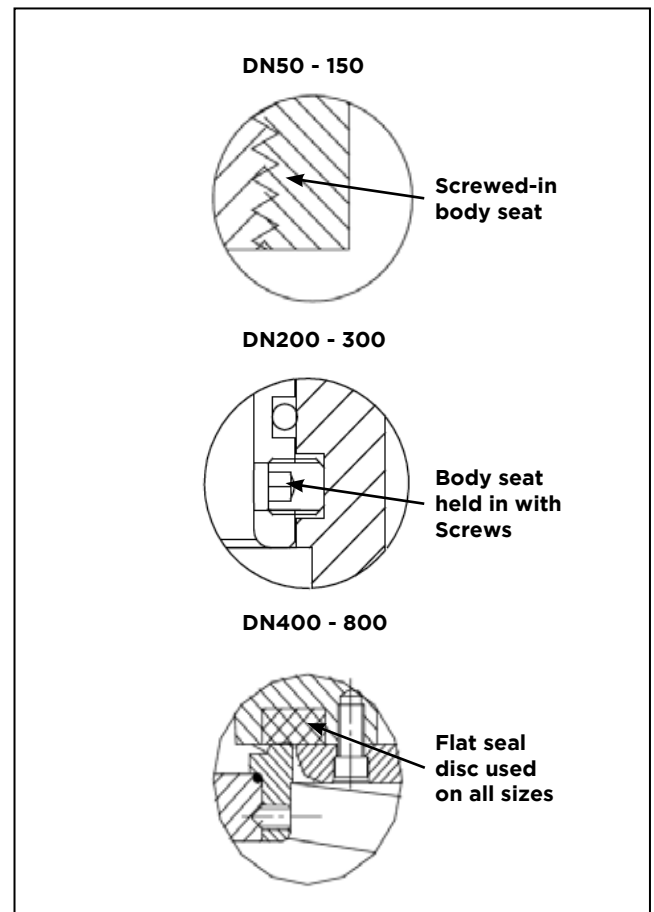

The Ultra Alpine ACV is one of the few valves of its kind with a cavitation resistance which enables it to reduce pressure in a 4:1 ratio with a modified design whereas most competitors can only achieve a 3:1 ratio.

Ultra supply different types of Control Valve designs up to 150bar.

A900 / R900-Main Valve DN50-DN350

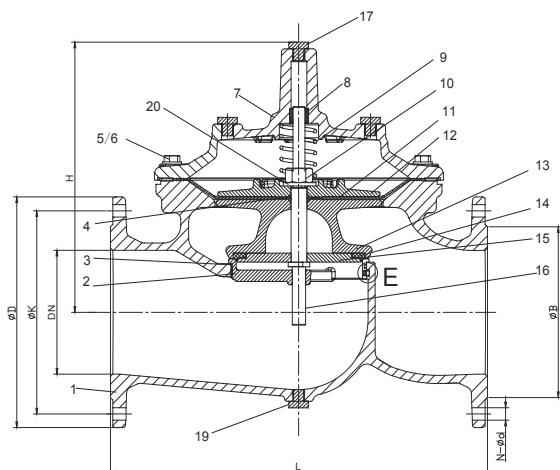

E

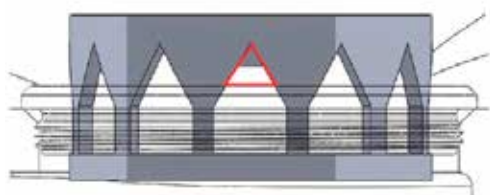
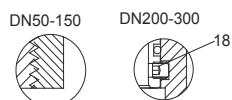

Parts List

No.	Description	Material	Standard
1	Body	Ductile Iron	GJS 500-7
2	Seat	Stainless Steel	AISI 304/316
3	O-ring	Rubber	NBR
4	O-ring	Rubber	NBR
5	Bolt	Stainless Steel	A2/A4
6	Washer	Stainless Steel	A2/A4
7	Bonnet	Ductile Iron	GJS 500-7
8	Bush	Bronze	C61900
9	Spring	Stainless Steel	AISI 304/316
10	Caulking Nut	Stainless Steel	A4
11	Diaphragm	Nylon Reinforced Rubber	EPDM +Nylon Fabric
12	Fixing holder	Ductile Iron	GJS 500-7
13	Disc Holder	Ductile Iron	GJS 500-7
14	Seal	Rubber	EPDM
15	Seat Retainer	Stainless Steel	AISI 304/316
16	Stem	Stainless Steel	AISI 304/316
17	Plug	Stainless Steel	AISI 304/316
18	Screw	Stainless Steel	A2/A4
19	Plug	Stainless Steel	A2/A4
20	Washer	Stainless Steel	A2/A4

* Vport is an optional as Anti-cavitation kit

* Low flow stable control

Dimension:

Unit: mm

DN	Model Code	L	ØD			ØK			H		N-Ød			ØB		
			PN10	PN16	PN25	PN10	PN16	PN25	A900	R900	PN10	PN16	PN25	PN10	PN16	PN25
50	A900-0050	230	165	165	165	125	125	125	177		4-Ø19	4-Ø19	4-Ø19	Ø99	Ø99	Ø99
65	A900-0065	290	185	185	185	145	145	145	202	180	4-Ø19	4-Ø19	8-Ø19	Ø118	Ø118	Ø118
80	A900-0080	310	200	200	200	160	160	160	219	182	8-Ø19	8-Ø19	8-Ø19	Ø132	Ø132	Ø132
100	A900-0100	350	220	220	235	180	180	190	243	225	8-Ø19	8-Ø19	8-Ø23	Ø156	Ø156	Ø156
125	A900-0125	400	250	250	270	210	210	220		243	8-Ø19	8-Ø19	8-Ø28	Ø156	Ø156	Ø156
150	A900-0150	480	285	285	300	240	240	250	333	243	8-Ø23	8-Ø23	8-Ø28	Ø211	Ø211	Ø211
200	A900-0200	600	340	340	360	295	295	310	428	345	8-Ø23	12-Ø23	12-Ø28	Ø266	Ø266	Ø274
250	A900-0250	730	405	405	425	350	355	370	478	440	12-Ø23	12-Ø28	12-Ø31	Ø319	Ø319	Ø330
300	A900-0300	850	460	460	485	400	410	430	538	450	2-Ø23	12-Ø28	16-Ø31	Ø370	Ø370	Ø389
350	A900-0350	980	520	520	555	460	470	490		550	16-Ø23	16-Ø28	16-Ø34	Ø429	Ø429	Ø448

NOTE: 1. *DN125/350 use same internal as DN100/300

2. AISI 304 factory standard material. consult factory for AISI 316 material.

A900 R900-Main Valve DN400-DN800

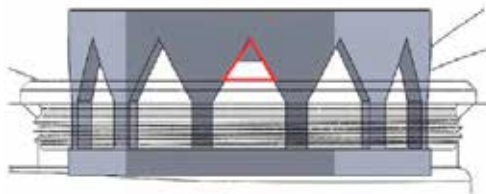
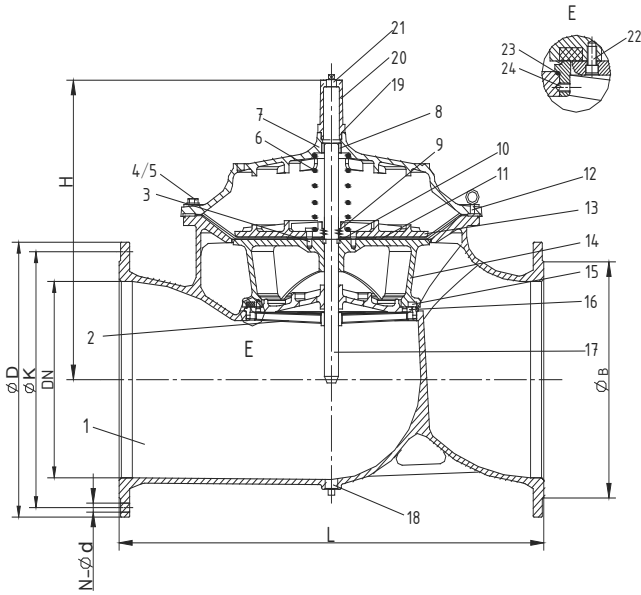

Parts List

No.	Description	Material	Standard
1	Body	Ductile Iron	GJS 500-7
2	Seat	Stainless Steel	AISI 304/316
3	Screw	Stainless Steel	A2/A4
4	Screw	Stainless Steel	A2/A4
5	Screw	Stainless Steel	A2/A4
6	Spring	Stainless Steel	AISI 304/316
7	Bonnet	Ductile Iron	GJS 500-7
8	Bush	Bronze	C61900
9	O-ring	Rubber	NBR
10	Fix Washer	Bronze	C61900
11	Diaphragm	Nylon Reinforced Rubber	EPDM +Nylon Fabric
12	Eye Bolts	Carbon Steel	1040
13	Fixing Holder	Ductile Iron	GJS 500-7
14	Disc Holder	Ductile Iron	GJS 500-7
15	Seal	Rubber	EPDM
16	Seal Retainer	Ductile Iron	GJS 500-7
17	Stem	Stainless Steel	AISI 304/316
18	Plug	Stainless Steel	AISI 304/316
19	O-ring	Rubber	NBR
20	Cap	Ductile Iron	GJS 500-7
21	Plug	Stainless Steel	AISI 304/316
22	Screw	Stainless Steel	A2/A4
23	O-ring	Rubber	NBR
24	Screw	Stainless Steel	A2/A4

* Vport is an optional as Anti-cavitation kit

* Low flow stable control

Unit: mm

Dimension:

DN	Model Code	L	H			ØD			ØK			N-Ød			ØB		
			A900	R900	PN10	PN16	PN25	PN10	PN16	PN25	PN10	PN16	PN25	PN10	PN16	PN25	
400	A900-0400	1100	710	550	580	580	620	515	525	550	16-Ø28	16-Ø31	16-Ø37	480	480	503	
*450	A900-0450	1200		720	640	640	670	565	585	600	20-Ø28	20-Ø31	20-Ø37	530	548	548	
500	A900-0500	1250	822	725	715	715	730	620	650	660	20-Ø28	20-Ø34	20-Ø37	582	609	609	
600	A900-0600	1450	885	842	840	840	845	725	770	770	20-Ø31	20-Ø37	20-Ø40	682	720	720	
*700	A900-0700	1650		910	910	910	960	840	840	875	24-Ø31	24-Ø37	24-Ø43	682	720	720	
800	A900-0800	1850		1260	1025	1025	1085	950	950	990	24-Ø34	24-Ø40	24-Ø49	901	901	928	

Note: 1. *DN450/700 use same internal as DN400/600.

2. AISI 304 factory standard material. consult factory for AISI 316 material.

System of Operation

The Ultra Alpine ACV hydraulic control valve system is based on a robust, reliable, hydraulically operated, diaphragm actuated valve with which various controls may be incorporated, either singularly or in combination with each other to provide any conceivable operation that may be required for regulating the flow of water.

Functions

Up to 1500 combinations of pilot arrangements are available with comparison model numbers of main competitors:

Bermad	Cla-Val	Ultra Alpine ACV	Description
770	40-01	114	Rate of Flow Control
730	50-01	116	Pressure Relief / Sustaining
730-20	51-01	116-5	Pressure Sustaining & Check
735	52-03	116-52	Surge Anticipator
730-55	58-01	116-31	Pressure Sustaining & Solenoid
740Q-B	60-11	513-5	Dual Chamber Booster Pump Control
740Q	60-31	413-21	Single Chamber Booster Pump Control
745Q-B	61-02	513-6	Deep Well Pump Control
760-03	81-02	118-3	Non-Surge Check Valve with opening and closing speed controls
720	90-01	115	Pressure Reducing
720-20	91-01	115-3	Pressure Reducing & Check
723	92-01	115-2	Pressure Reducing & Sustaining
720-55	93-01	115-4	Pressure Reducing & Solenoid
750-66	124-01	110-14	On-Off Float Control
750-60	129-01	110-10	Modulating Float Control
710	136-01A	113-12	Solenoid Control
750-80	210-01	127-1	One Way Flow Altitude Control
750-87	210-06	127-2	Two Way Flow Altitude Control

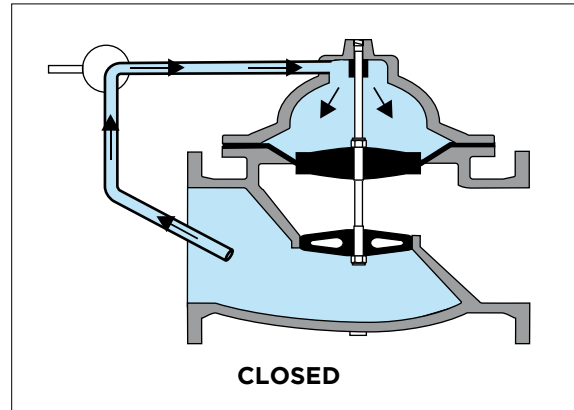

CLOSED

VALVE CLOSED

The valve closes when pressure is directed into the valve cover chamber above the diaphragm. An independent operating supply may be used if its pressure is equal to, or greater than the pressure at the valve inlet.

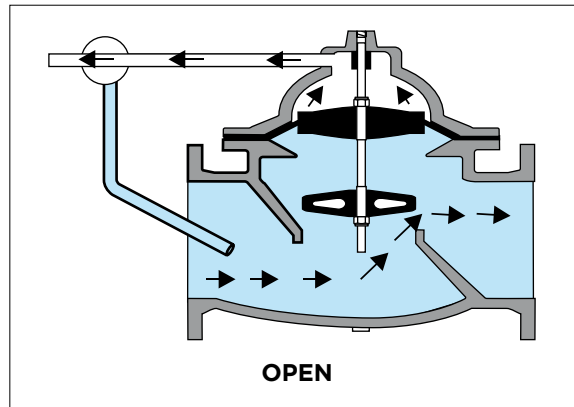

OPEN

VALVE OPEN

The valve opens fully when there is no pressure in the cover chamber and at least 50 kPa line pressure at the valve inlet.

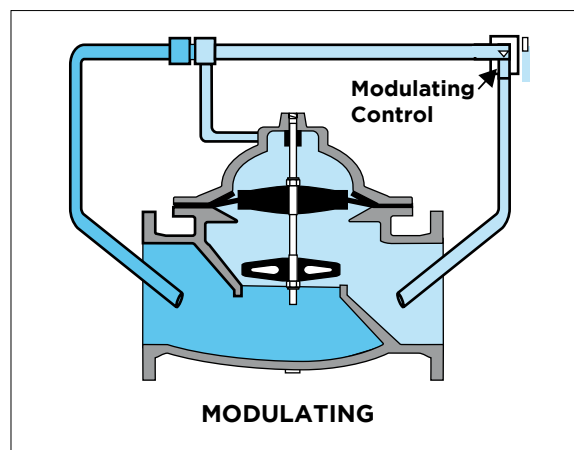

MODULATING

VALVE MODULATING

Modulating action can be obtained by installing a control system to the basic valve. Various controls are available to modulate and compensate for pressure, flow rate, or liquid level changes.

Level Control Applications

The Ultra Alpine ACV valve can be used to control Water Level in Reservoirs and Tanks in a variety of different ways depending on many factors such as Pressure and Flow conditions and configurations of the installation. A logical way to classify the different methods to control level is by On-off or Modulation. Within both groups an almost unlimited combination of other functions can be added such as Pressure Sustaining, rate of Flow control, Solenoid override etc, which makes the Ultra Alpine ACV Control valve very versatile. In both groups the choice can be made to install the valve as a top-of-reservoir valve mounted inside (or outside) the reservoir, or as a bottom entry with the valve mounted on the bottom of the reservoir. Please note that a stilling well should be installed with the float pilot if water turbulence could affect the operation. The stilling well can be an appropriate diameter plastic pipe (normally 200mm).

Hydraulic Conditions

In order for Level control valves to operate effectively and provide long trouble-free life, flow and pressure conditions have to be investigated. Two pressure conditions can create problems i.e.

1) High Pressure

Dam (or reservoir) control valves have always been susceptible to two potential problems caused by high pressure conditions which can be overcome if one is aware of what the problems are.

Cavitation - Most control valves can handle a pressure drop ratio of no more than 3:1. Because of its unique features the Ultra Alpine ACV control valve can handle a 4:1 pressure drop ratio. Even so in a Level control application if one assumes a back pressure of 1 bar from the head of the reservoir downstream of the valve, the valve can only effectively cope with 4 bar upstream in order to provide a long life.

High Flow Rates - If a level control valve is allowed to go fully open and dynamic head is above 1.5bar, a flow rate far beyond the recommended can occur which can cause further damage. In both of the above situations the extent of the valve's life will be determined by the level of the upstream pressure. If the discharge into the dam is free with the valve installed at the end of the line, the problem is not as severe because cavitation will occur outside the valve, but one still has the high velocity problem.

Our recommendations for these installations are outlined below.

- Upstream Dynamic head between 5 and 10 bar

Install a Flow control pilot on the Ultra Alpine ACV Level Control Valve to limit flow rate to an acceptable level and install an orifice plate downstream of the valve to provide an artificial back pressure. The valve will still

experience cavitation during the opening and closing cycles, but as long as the cycles are not too frequent and closing and opening speed is not too long, the above recommendations should ensure a reasonable valve life.

- Upstream Dynamic head over 10 bar

Install a Flow control pilot on the Ultra Alpine ACV Level Valve and install an additional Pressure Reducing valve upstream of the Level control valve. The Pressure Reducing valve can be either a pilot operated Ultra Alpine ACV valve or a Ultra Ratio Reducing valve which operates without a pilot and can handle pressure drops of up to 5:1.

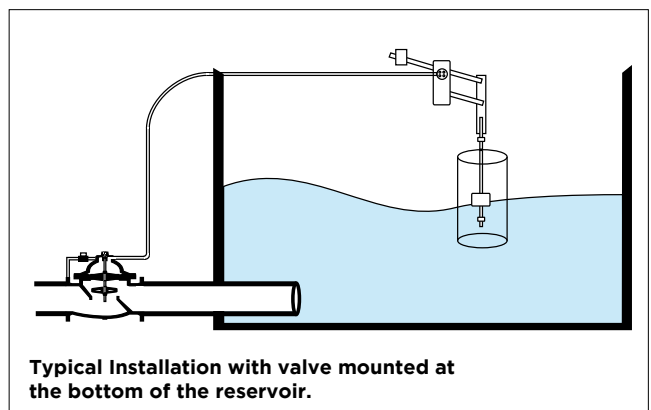
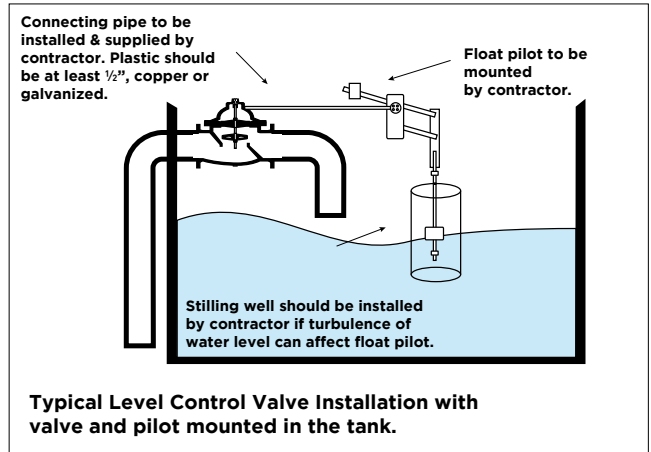

2) Low Pressure

Flowing line pressure should be 50kPa or more to ensure that sufficient head is available to open the valve fully. This assumes there is not pressure in the control chamber. The other factor to be aware of is that with the valve at the bottom of the reservoir and the float pilot at the top, the static head in the control tubing is the minimum pressure which can be achieved in the control chamber with the normal pilot hook-up. A "rule of thumb" which can be used to check this condition is as follows:

The flowing line pressure in PSI should be greater than or equal to the vertical distance in feet between the valve and the float pilot.

FIG BT110-10

Float Control - Modulating (Constant Level)

The FIG B110-10 maintains a constant level in storage tanks and reservoirs. Valve controlled flow into the tank is proportional to discharge flow, keeping the tank full.

NOTE: The modulating float control FIG B110-10, is remote mounted unless specified valve mounted. A stilling well around the float should be installed if the liquid surface is subject to turbulence, ripples or wind.

Quick Sizing: Valve size same as fill line or one size smaller if discharge line is smaller than the fill. Match size/capacity to discharge requirements.

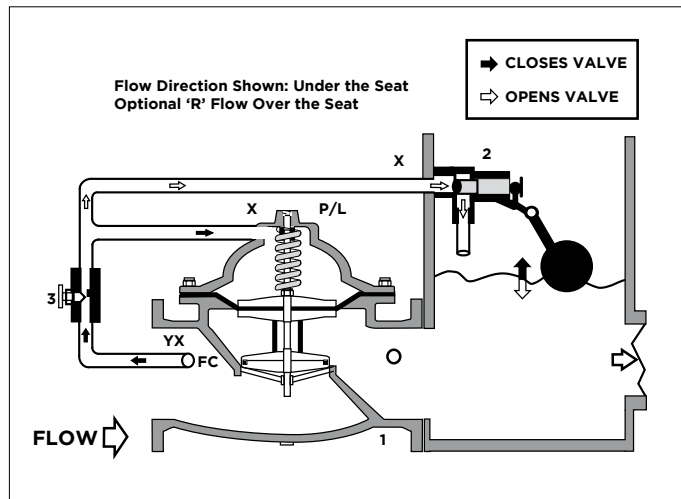

VALVE FUNCTION

- Maintains a constant liquid level in a tank.
- Remote mounted pilot is sensitive to slight changes in level and controls main valve:
 - Opens when level drops
 - Closes when level rises

ACCESSORIES

Located as indicated
Included as marked

- X - Isolation Cocks
- Y - Y Strainer
- P - Position Indicator
- FC - Flo-Clean Strainer
- L - Limit Switch

COMPONENTS

1. Main Valve
2. Fig. 10-11 Modulating Float Control
3. Needle Valve - Adj. Closing Speed

FIG BT110-14

Float Control-On/Off (Open/Close) Adj. Hi/Lo Levels

The FIG B110-14 opens fully when the level reaches the preset low point and shuts off drip tight when the high level is reached. The on/off ball valve pilot is equipped with a vertical rod which allows the float to rise and drop to the adjustable upper and lower stops.

NOTE: The pilot is remote mounted unless it is specified valve mounted. Standard equipped with brass rods and plastic floats. Stainless steel rods and floats are available. Provide a stilling well around the float if a liquid surface is subject to turbulence, ripples or wind.

Specify: If the Pilot is to be mounted on the valve. Contact Ultra staff if unsure about anything.

Quick Sizing: Valve size same as fill line.

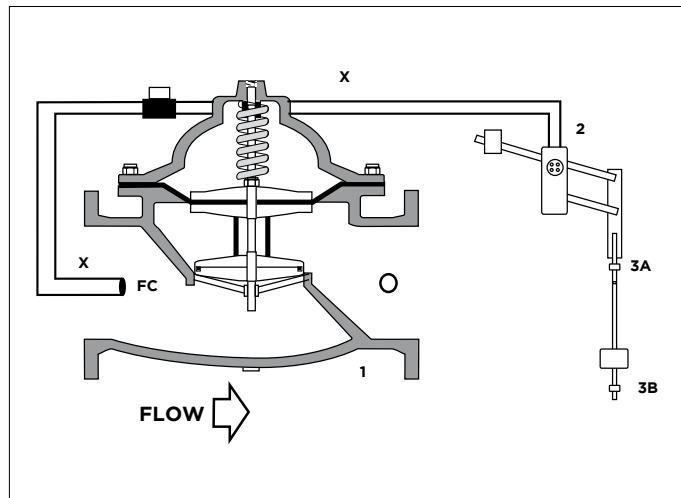

VALVE FUNCTION

- Valve opens when float reaches lower level stop (adjustable)
- Valve closes when float reaches upper level stop (adjustable)
- High and low level adjustments allows for calculated draw down
 - Opens when level drops
 - Closes when level rises

ACCESSORIES

Located as indicated
Included as marked
Large size valves may require an accelerator Pilot.

- X - Isolation Cocks
- Y - Y Strainer
- FC - Flo-Clean Strainer
- L - Limit Switch

COMPONENTS

1. Main Valve
2. Fig. 10-13 Float Pilot
3. Level Adjustment Stops
- 3A - Upper Level
- 3B - Lower Level



FIG BT127-1
Altitude Valve - One Way (Tank Fill)

Provides automatic filling of elevated tanks or reservoirs. When the altitude control senses a drop in level below the predetermined set-point, the valve opens to fill the tank. Supply pressure must be greater than static head pressure. Discharge of the tank is by a separate line.

Adjustable ranges:	1.5m - 6m
	3m - 22m
	15m - 60m

Quick Sizing: Valve size, line size or one size smaller.

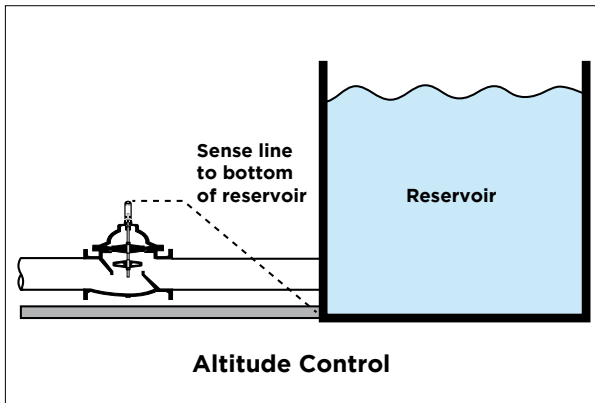

FIG BT127-1
Altitude Valve - Two Way Flows (Tank Fill & Discharge)

Provides automatic filling of elevated tanks or reservoirs. Supply pressure must be greater than static head pressure. When the altitude control senses a drop in level below the predetermined set-point, the valve opens to fill the tank. The valve opens for tank discharge when tank head pressure is greater than valve inlet pressure.

Adjustment ranges:	1m - 5m
	5m - 12m
	10m - 32m
	22m - 40m

Quick Sizing: Valve size, line size or one size smaller.

Points to consider: Tank discharge flow requires a valve inlet (system pressure) to be 13 kPa less than tank head pressure.

Two way flows allowing water in and out through the same line can be done with a modified schematic

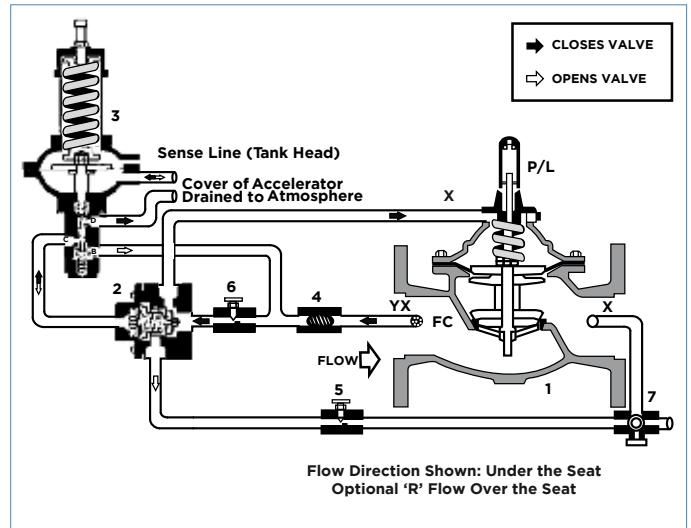

VALVE FUNCTION

- Closes when reservoir level reaches pilot setting
- Opens approximately 300mm lower.

ACCESSORIES

Located as indicated
Included as marked

- X - Isolation Cocks
- Y - Y Strainer (Eliminates Flo-Clean)
- L - Limit Switch

COMPONENTS

1. Main Valve
 2. Fig. 22-1 Accelerator Control for sizes larger than 150mm.
 3. Fig. 27 Altitude Control
 4. Check Valve
 5. Needle Valve - Adj. Opening Speed
 6. Needle Valve - Adj. Closing Speed
 7. 3-Way Ball Valve
- P - Position Indicator
FC - Flo-Clean Strainer

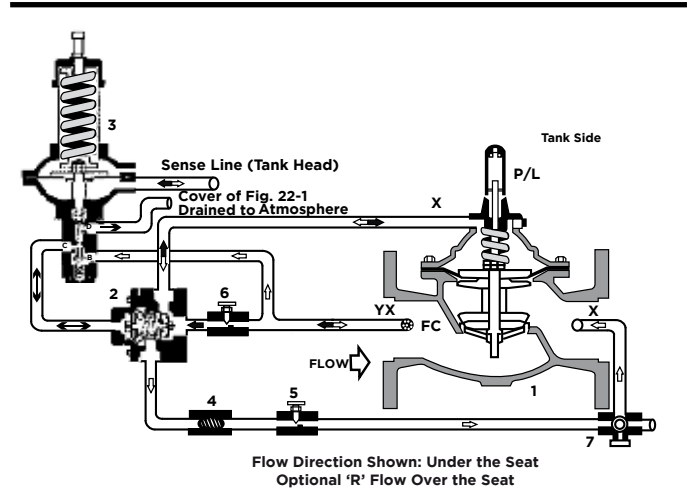

VALVE FUNCTION

- Tank fill
- Opens when reservoir level drops below pilot setting (adjustable)
- Closes when reservoir level reaches pilot setting
- Tank Discharge
- Opens when valve inlet / system pressure is below tank head

- X - Isolation Cocks
- Y - Y Strainer
- FC - Flo-Clean Stainer
- L - Limit Switch

COMPONENTS

1. Main Valve
 2. Fig. 22-1 Accelerator Control for sizes larger than 150mm.
 3. Fig. 27 Altitude Control
 4. Check Valve
 5. Needle Valve - Adj. Opening Speed
 6. Needle Valve - Adj. Closing Speed
 7. 3-Way Ball Valve
- P - Position Indicator

ACCESSORIES

Located as indicated
Included as marked

FIG BT115

Pressure Reducing

Automatically reduces a higher pressure to a constant lower outlet pressure regardless of changing flow rate and / or varying inlet pressure. Refer to FIG B115-7 for dead-end systems and / or systems using high demand, on-off equipment.

NOTE:

Adjustment range:

2.5m - 21m

Lower range available check with Ultra Valves

QUICK SIZING:

Valve size one size smaller than line.

Points to consider:

- See Engineering Data - Pressure Reducing Sizing
- Check maximum and minimum flow
- Check pressure drop - pressure reducing valves or cavitation charts.

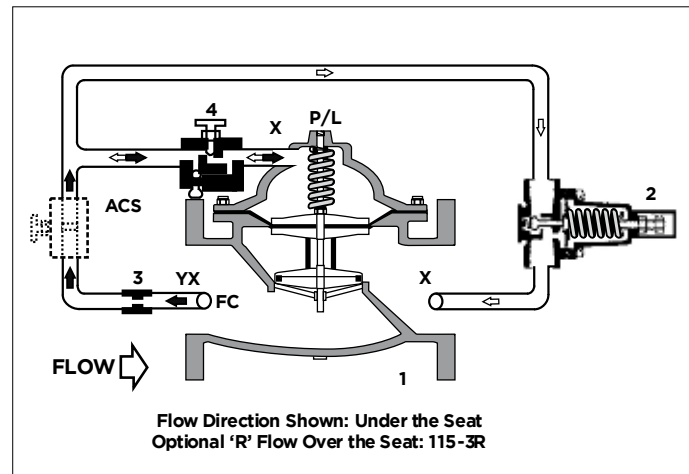

VALVE FUNCTION

- Reduce higher inlet pressure to constant lower outlet pressure (adjustable)

COMPONENTS

1. Main Valve
2. 263 Reducing Valve
3. Fixed Orifice
4. Flow Control - Adj. Opening Speed

ACCESSORIES

Located as indicated
Included as marked

- X - Isolation Cocks
- Y - Y Strainer
- P - Position Indicator
- FC - Flo-Clean Strainer
- L - Limit Switch
- AOS - Adjustable Opening Speed

Pressure Reducing

"V-Port is used for improved low flow stability and anti Cavitation trim".

The V Port is available in single or Double V Port for the more difficult applications. This is also very useful in other high cavitation areas such as Level Control.



V-PORT

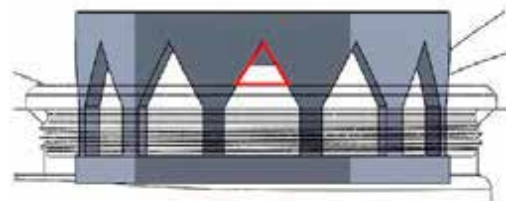

Single V Port



Double V Port

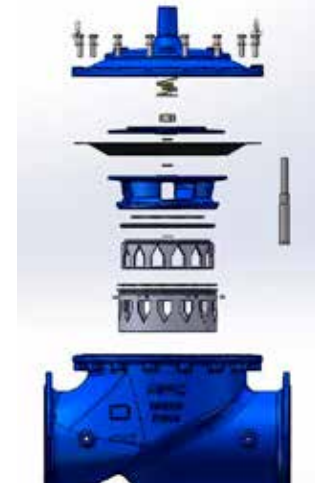

Double V-Port for extreme conditions consult Ultra Valves

Ultra Alpine ACV Ratio Reducing Valve

The Ultra Alpine ACV Ratio Reducing valve consists of a Piston inside a body with no external piloting and which cannot be adjusted or tampered with. The valve simply reduces an upstream pressure to a downstream pressure in the Ratio chosen ie if upstream pressure is say 20bar you can reduce this pressure to 10bar by choosing a 2:1 Ratio Reducing valve or 20bar to 6.7bar by choosing a 3:1 Ratio Reducing valve. The Ratio Reducing valve is the simplest form of Pressure Reduction and if used in the right applications, will provide many years of problem free operation.



Available in:

Sizes: 50mm to 400mm

Pressure ratings: 16bar, 25bar, 40bar, 64bar, 100bar, 150bar

Available Ratio's: 2:1, 3:1, 4:1, 5:1 and fractions if required

Accuracy: Approximately 10%

Size	L
50mm	80
80mm	110
100mm	120
150mm	160
200mm	200
250mm	250
300mm	
400mm	

- 1. Body
- 2. Piston
- 3. O-ring
- 4. Main Seal

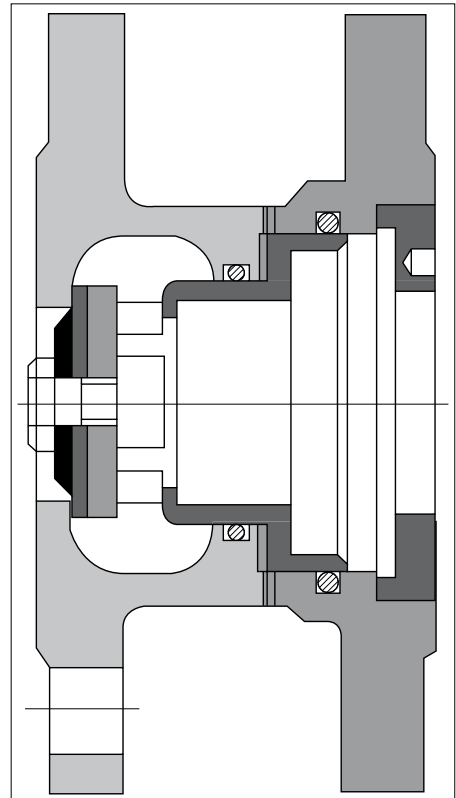

*** L given is for 16bar valves**

For higher pressures L is longer by the increased flange thickness

Material of Construction Alternatives	
Body	Cast iron, WCB Steel, Stainless Steel
Piston	Brass, Stainless Steel
Main Seal	Buna N

Ultra Direct Acting Pressure Reducing Valve

The Ultra ACV Direct Acting Pressure Reducing valve is used where adjustability is required but a simpler solution is desired.

Available in:

Sizes: 15mm to 200mm

Pressure rating: 16bar, 25bar, 40bar, 64bar, 100bar

Standard body material: WCB Steel 316 SS available



Size	L		H	
	16-25	40-64	16-25	40-64
20mm	160	160	310	310
25mm	180	200	350	470
32mm	200	220	355	475
50mm	250	270	445	465
80mm	310	330	465	500
100mm	350	380	525	545
150mm	450	450	770	865

Parts List

- | | |
|--------------------|----------------------|
| 1. Body | 13. Bolt |
| 2. Bottom Cover | 14. Nut |
| 3. Gasket | 15. O-ring |
| 4. Nut | 16. O-ring |
| 5. Disc | 17. Spring Washer |
| 6. Sealing Ring | 18. Nut |
| 7. Seat | 19. Adjusting Spring |
| 8. Stem | 20. Upper Cover |
| 9. O-ring | 21. Spring Retainer |
| 10. Gasket | 22. Adjusting Screw |
| 11. O-ring | 23. Cover |
| 12. Cylinder Liner | |

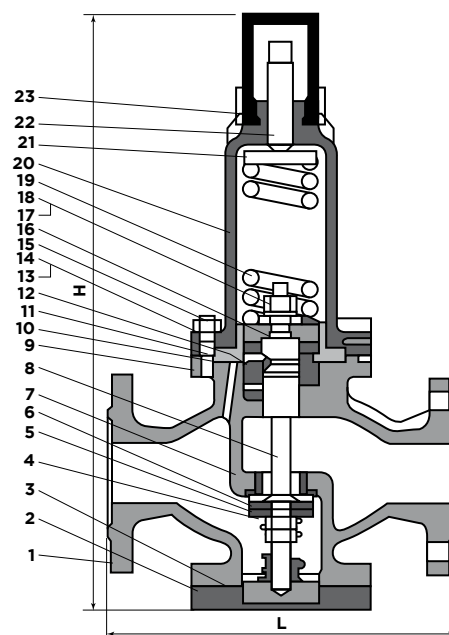
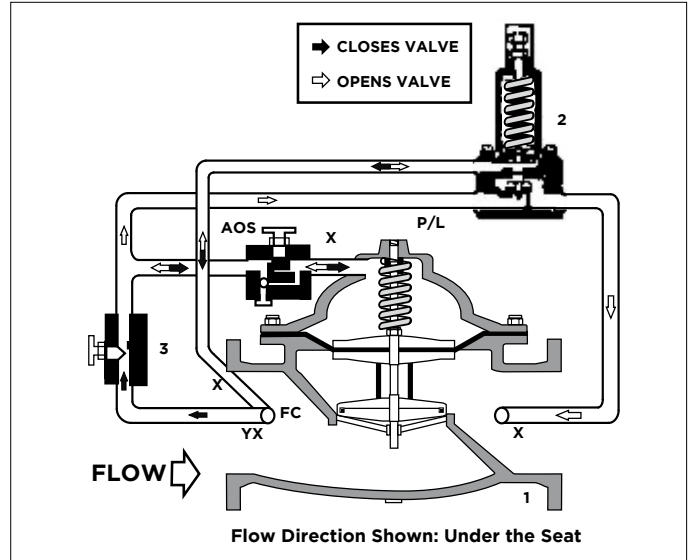

FIG BT116

Pressure Relief / Sustaining

Installed on a bypass line, mainline pressure is accurately controlled by relief of excess pressure. Installed in a mainline it prevents upstream pressure from dropping below a preset minimum. **For very fast reaction requirement refer to Ultra for info on gas loaded surge relief valve.**

NOTE:
Adjustment range:
Standard: 2.5bar - 21bar
Optional: 0-204 kPa
100-2040 kPa



116 RELIEF

Quick Sizing: Valve size one or two sizes smaller than main line.

Points to Consider:

- Refer to Engineering Data - Flow Capacity Chart

116 SUSTAINING

Quick Sizing: Valve size same as line.

Points to Consider:

- Refer to Engineering Data - Flow Capacity Chart
- Pressure drops at required flow
- Refer to Engineering Data - Pressure Drop Chart

VALVE FUNCTION

Maintain constant upstream pressure (inlet to valve) by relieving excess Pressure.

COMPONENTS

1. Main Valve
2. PV20C Sustaining Control
3. Needle Valve - Adj. Closing Speed

ACCESSORIES

Located as indicated
 Included as marked

- X - Isolation Cocks
- Y - Y-Strainer
- P - Position Indicator
- FC - Flo-Clean Strainer
- L - Limit Switch
- AOS - Adj. Opening Speed

Valve Size - mm	50	80	100	150	200	250	300	350	400	600
Maximum Continuous Flow Rate l/s (water)	13	30	50	114	200	310	440	540	695	1700
Minimum Intermittent Flow Rate l/s (water)	30	65	114	310	440	695	1010	1200	1580	2300

If the valve is to be used as a "safety" Relief valve the flow rates in the table can be exceeded.

High Pressure Sustaining as Pump Bypass

Using the Ratio Reducing valve and Ultra Alpine Pressure Sustaining valve, Ultra have a Unique solution for high pressure Pump Bypass, for pressures up to 50bar. Multiple Ratio Reducing valves can be used to ensure smooth operation and no Cavitation.

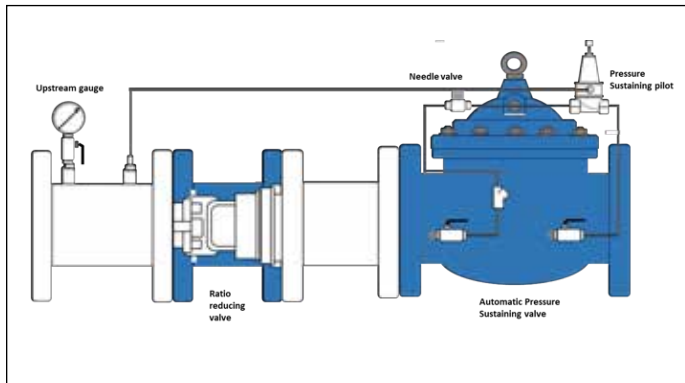

High Pressure Sustaining

Ultra Alpine Pressure Sustaining valve



FIG BT113-12

Solenoid On/Off (Open/Close)

Operated by a 3-way solenoid, the main valve opens fully or closed drip-tight depending upon the actuation position of the solenoid, energized to open/energized to close. The valve may be remotely operated by timers, relays, probes or any triggered device to the solenoid. The valve can be operated with 2 x 2-way solenoids for modulating control from a PLC.

NOTE:

- Energized to open valve.
- Optional: energized to close valve.
- At time of order, advise our factory manager of your system working pressure for correct solenoid selection. 110-220 VAC, 50-60 Hz standard
- Optional: specify voltage required.
- Enclosure General Purpose (NEMA 1,2,3,3S,4,4X)
- Optional: explosion proof (NEMA 3,3S,4,4X,6,6P,9)
- Manual operator standard
- Optional: Opening and/or closing speed.

Quick Sizing: Valve size same as line or one size smaller.

Points to consider:

- Refer to Engineering Data - Flow Capacity Chart
- Pressures drop at required flow
- Refer to Engineering Data - Pressure Drop Chart

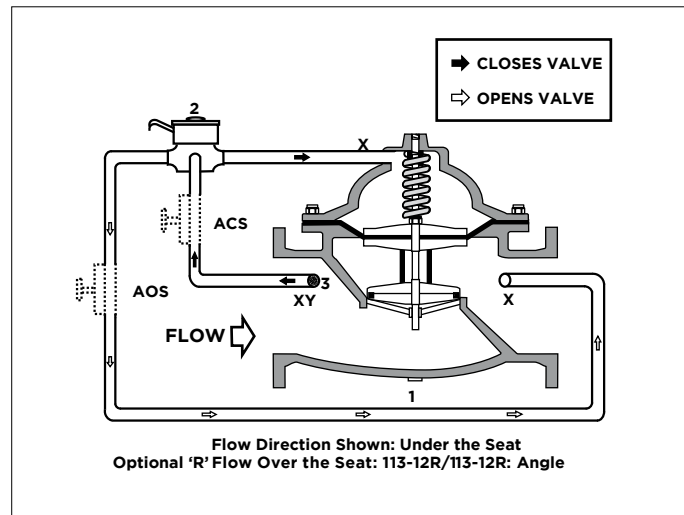

VALVE FUNCTION

- Electrically operated on/off (open/close) control valves

COMPONENTS

1. Main Valve
2. 3-Way Solenoid
3. Flo-Clean Strainer

ACCESSORIES

Located as indicated
Included as marked

- X - Isolation Cocks
- Y - Y Strainer (Eliminates Flo-Clean)
- ACS - Adj. Closing Speed
- AOS - Adj. Opening Speed

Fig BT113-dual

Dual Solenoid Control

This configuration has 2 x solenoids and which enables the valve to be used as Electronic Control valve. Each solenoid is individually Energised to “step” the valve into the appropriate position as governed by the client’s PLC or other Electronic controller. This is a successful and inexpensive method to achieve accurate control without expensive actuators as the valve is driven by the fluid it’s controlling



FIG BR113-45 TO BT113-21

Booster Pump Control (Valves 150mm and smaller)

With the Ultra Alpine range of valves many different variations of Pump Control valves are available. The simple option of Solenoid valve with Limit switch assembly will mostly have just a Normally closed 3-way solenoid and the limit switch assembly which will be "tied" into the pump's controls. Accelerator relays can be added for sizes above 150mm to ensure that the speed of valve cycle can be fast enough. Pressure Sustaining features can be added to ensure the pump stays on its efficiency curve. Double chamber valves are available when low pressure drop is required. Below are some of the variations available.

NOTE:

Energized to open valve.
At time of order, advise factory actual system working pressure for correct solenoid selection.
110-120 VAC, 50-60 Hz standard
Optional: specify voltage required.
Solenoid enclosure NEMA 1,2,3,3S,4,4X
Optional: explosion proof NEMA 3,3S,4,4X,6,6P,7,9
Manual operator standard
Limit switch enclosure general purposes
Optional: explosion proof.
Standard with adjustable opening and closing speed.

Quick Sizing: Valve size same as line.

Points to consider:

- Refer to Engineering Data - Flow Capacity Chart

- Pressures drop at required flow
- Refer to Engineering Data - Pressure Drop Chart

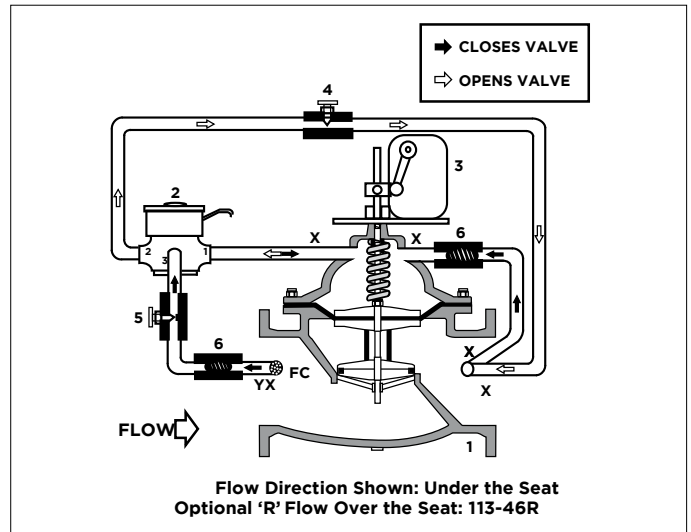

VALVE FUNCTION

- Opens at a controlled rate on the pump start-up (adjustable)
- Closes at a controlled rate on pump shut-off (adjustable)
- Valve and pumps are electrically interlocked so that power is shut-off when the valve is in near closed position

COMPONENTS

1. Main Valve
2. 3-Way Solenoid
3. Fig. 51 Limit Switch FC - Flow Clean Strainer
4. Speed
5. Needle Valve - Adj. Closing Speed
6. Check Valve

ACCESSORIES

Located as indicated
 Included as marked

- X - Isolation Cocks
- Y - Y Strainer

FIG BT413-21

Booster Pump Control / Mechanical Lift Check

A solenoid operated pump control for controlled opening and closing on a pump start-up and shut down. Equipped with hydraulic check features to close valve on pressure reversal and shut-off pump in an event of pump failure. Valve and pump operations are Interlocked by a limit switch assembly.

NOTE:

Energized to open valve.
At time of order, advise factory actual system working pressure for correct solenoid selection.
110-220 VAC, 50-60 Hz standard
Optional: specify voltage required.
Solenoid enclosure NEMA 1,2,3,3S,4,4X
Optional: explosion proof NEMA 3,3S,4,4X,6,6P,7,9
Manual operator standard
Limit switch enclosure general purposes
Optional: explosion proof.
Standard with adjustable opening and closing speed.

Quick Sizing: Valve size same as line.

Points to consider:

- Refer to Engineering Data - Flow Capacity Chart
- Pressures drop at required flow
- Refer to Engineering Data - Pressure Drop Chart

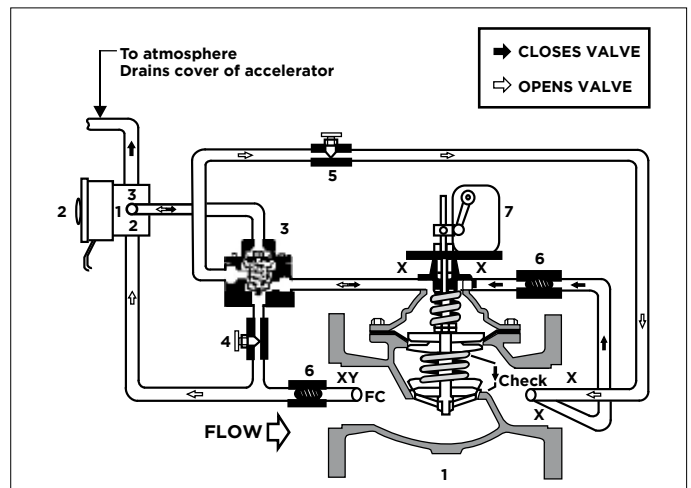

VALVE FUNCTION

- Opens at a controlled rate on the pump start-up (adjustable)
- Closes at a controlled rate on pump shut-off (adjustable)
- Valve and pumps are electrically interlocked so that power is shut-off when the valve is in near closed position
- Mechanical lift-check provides quick closure of the valve to prevent reverse flow

COMPONENTS

1. Main Valve Opening Speed
2. 3-Way Solenoid
3. Fig. 22-1 Accelerator Control
4. Needle Valve - Adj. Closing Speed
5. Needle Valve - Adj.
6. Check Valve
7. Fig. 51 Limit Switch

ACCESSORIES

Located as indicated
 Included as marked

- X - Isolation Cocks
- Y - Y Strainer
- FC - Flo-Cleaner Strainer

A7XD Pump Control with Dual chamber and mechanical Passive action

This configuration does not use a solenoid and acts like a check valve controlled by upstream and downstream pressures. A limit switch assembly is connected to the pump panel to indicate closed or open valve.

This valve will close quickly for 80% of the stroke and slow down for the last 20% to avoid water hammer.

This feature is achieved through manipulation of the internal components and is a patented option with the Ultra Alpine Control valves.



Draw Align Left 2

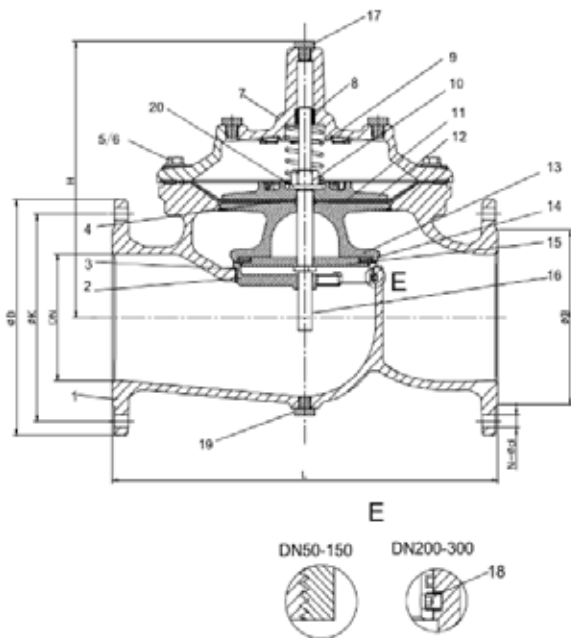

PARTS LIST - SPECIFICATIONS

No	Description	Material	Standard
1	Body	Ductile Iron	GJS 500 – 7
2	Seat	Stainless Steel	AISI 304 / 316
3	O-ring	Rubber	NBR
4	O-ring	Rubber	NBR
5	Bolt	Stainless Steel	A2 / A4
6	Washer	Stainless Steel	A2 / A4
7	Bonnet	Ductile Iron	GJS 500 – 7
8	Bush	Bronze	C61900
9	Spring	Stainless Steel	AISI 304 / 316
10	Caulking Nut	Stainless Steel	A4
11	Diaphragm	Nylon Reinforced Rubber	EPDM + Nylon Fabric
12	Fixing Holder	Ductile Iron	GJS 500 – 7
13	Disc Holder	Ductile Iron	GJS 500 – 7
14	Seal	Rubber	EPDM
15	Seal Retainer	Stainless Steel	AISI 304 / 316
16	Stem	Stainless Steel	AISI 304 / 316
17	Plug	Stainless Steel	AISI 304 / 316
18	Screw	Stainless Steel	A2 / A4
19	Plug	Stainless Steel	A2 / A4
20	Washer	Stainless Steel	A2 / A4

A76D is a double chamber Pump Control with Solenoid and Limit switch assembly.

On pump start-up the PLC controller will energize solenoid 4-1 and 4-4 which opens the valve fully to minimize head loss. The needle valves can be adjusted to adjust opening and closing speed.

On pump stop the PLC will energize solenoids 4-2 and 4-4 and close the valve slowly. After valve closure, the limit switch on the valve will send signal to the PLC to shut the pump. This active protection will prevent Water Hammer

After a Power failure the A76D will act like a non-slam check valve and will close quickly to minimize Water Hammer.



ULTRA / ALPINE SERIES

BT113-21E Electronic Pump Control Valve

LEGEND

- 1 Upstream ball valve
- 2 Upstream pressure gauge
- 3 Y Strainer
- 4 A2 3 way accelerator
- 5 S2 3 way solenoid valve
- 6 Lower chamber flow controller
- 7 A1 3 way accelerator
- 8 S1 3 way solenoid valve
- 9 Upper chamber flow controller
- 10 Limit switch assembly
- 11 Downstream ball valve

De-Energizing the solenoids will open the valve

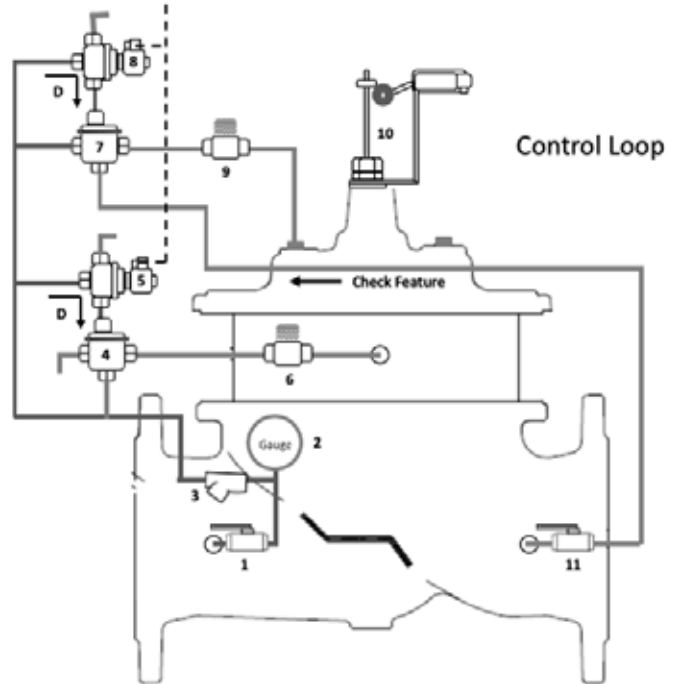

FIG BT114

Rate Of Flow

“R” Indicates flow over the seat (fail closed)

Maintains a constant flow rate, adjustable, regardless of fluctuations in line pressure. The rate of flow pilot senses the differential pressures across a thin edged orifice plate mounted in the valve inlet flange. It responds to changes in pressure and modulates the main valve to maintain the desired flow.

SPECIFY:

Desired flow rates at time of order.

FIG 114R: Flow over the seat (fail closed)

FIG 114: Flow under the seat (fail open)

Additional combination functions:

114-1R Rate of Flow / Solenoid On-Off

114-2R Rate of Flow / Pressure Reducing

114-8R Rate of Flow / Pressure Sustaining

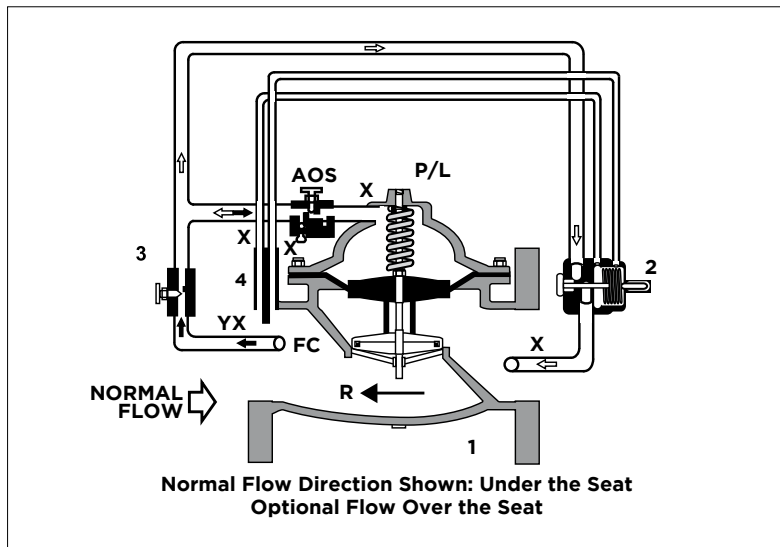

VALVE FUNCTION

Limits flow rate to a constant preset maximum (adjustable)

ACCESSORIES

Located as indicated
Included as marked

COMPONENTS

1. Main Valve
2. Fi 14 Rate of Flow Control pilot
3. Needle Valve - Adj. Closing Speed
4. Orifice Plate

- AOS - Adj. Opening Speed
- X - Isolation Cocks
- Y - Y Strainer
- FC - Flo-Clean Strainer
- P - Position Indicator
- L - Limit Switch

Maximum Flow Rate Litre / Second	14	30	50	115	200	310	440	550	700	1700
Minimum Flow Rate Litre / Second	1	2	3	6	12	19	25	31	53	190
Valve Size - mm	50	80	100	150	200	250	300	350	400	600



Quick Sizing: Stay within parameters of a capacity chart (below)

Points to consider:

- Orifice plate sized per application and per your acceptable pressure drop. For better accuracy the Orifice Plate should be installed on the valve inlet.

Maric Flow Control Valves

A totally different form of Flow Control (called Maric) is also available from Ultra. This product was developed in Australia and has been evolved into one of the best forms of Flow Control available. The bodies are now manufactured in South Africa.

Its benefits are:

- Simplicity
- Tamperproof
- Self Cleaning
- Non-Adjustable

The Maric is available in many different body configurations as per picture.

Pressure rating: Up to 20bar

Sizes: from 10mm to 400mm

Used on Higher pressure systems (such as Gland service water) together with Pressure control systems. Check with Ultra staff



Surge Relief Control

“UltraValves have many years of experience in Surge Relief solutions. Surge Relief Control valves are available in various options as described in the next few pages. Air valves and check valves play a big role and of which UCV have a wide range with various options. Surge tanks of both the Bladder and Compressor type are available as well as assistance with doing Complete Water Hammer analysis of systems.



FIG BT116-52

Surge Anticipator Relief / Remote Sense

Used in pumping systems to protect equipment from damaging pressure surges or waves caused by rapid changes of flow within the pipeline. The 116-52 responds by opening at a preset low pressure setting, allowing for quick relief of the returning high pressure wave. The valve remains open as the integral accumulator is charged and then closes. This prevents possible excess system drainage should pressure not return to/above the low pressure setting. It is also equipped with a high pressure control pilot which allows for high pressure relief service.

NOTE:

Adjustment range:
Low pressure : standard 20-1360 kPa, optional 0-204 kPa.
High pressure: standard 20-1360 kPa, optional 0-204, 100-2040 kPa

Quick Sizing: Rule of thumb says 1/3 of Pipe size.
 If critical discuss with Ultra Staff.

Ultra also supply a locally manufactured Gas Loaded Surge Relief Valve for pressures up to 150bar.

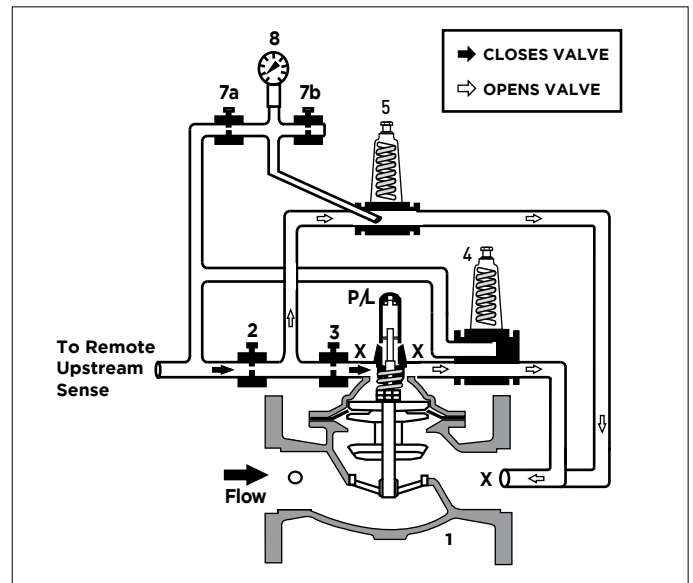

VALVE FUNCTION

Maintain constant upstream pressure (inlet to valve) by relieving excess Pressure.

COMPONENTS

1. Main Valve
2. PV20C Sustaining Control
3. Needle Valve - Adj. Closing Speed

ACCESSORIES

Located as indicated
 Included as marked

- X - Isolation Cocks
- Y - Y-Strainer
- P - Position Indicator
- FC - Flo-Clean Strainer
- L - Limit Switch
- AOS - Adj. Opening Speed

Valve Size - mm	50	80	100	150	200	250	300	350	400	600
Maximum Continuous Flow Rate l/s (water)	13	30	50	114	200	310	440	540	695	1700
Maximum Intermittent Flow Rate l/s (water)	30	65	114	310	440	695	1010	1200	1580	2300

Maximum continuous flow based on pipe line velocity of 6 Mtrs per second.
 Maximum intermittent flow based on pipe line velocity of 14 Mtrs per second.

Ultra Gas Loaded Surge Relief Valve

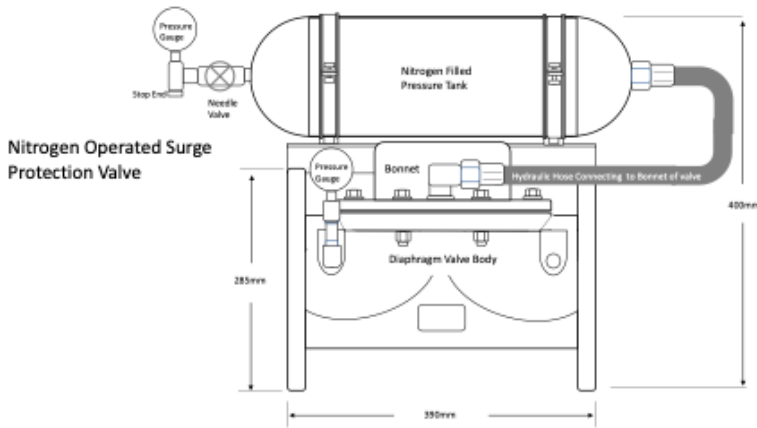

DIMENSIONS AND WEIGHTS

Valve Size		L		H		D		W		Weight					
										Cast Iron		Duct. Iron		Bronze	
mm	inch	mm	inch	mm	inch	mm	inch	mm	inch	kg	lbs	kg	lbs	kg	lbs
50	2	200	7.87	166	6.54	85	3.35	166	6.54	7.2	15.8	7.7	17	8	17.6
80LF	323	200	7.87	202	7.95	105	4.13	200	7.87	11	24.3	11.8	26		
80	3	285	11.22	200	7.87	105	4.13	200	7.87	17	37.5	18.2	40.1	19	42
100	4	305	12.01	230	9.06	110	4.33	230	9.06	22	48.5	24	53	24	53
150	6	390	15.35	314	12.36	145	5.71	300	11.8	46	101	49	108	51	112
200LF	868	385	15.16	350	13.78	170	6.69	365	14.4	50	110	54	119		
200	8	460	18.11	400	15.75	170	6.69	365	14.4	80	176	86	190	89	196
250	10	535	21.06	445	17.52	205	8.07	440	17.3	117	258	125	276	131	289
300	12	580	22.83	495	19.49	240	9.45	490	19.3	156	344	167	368	147	324

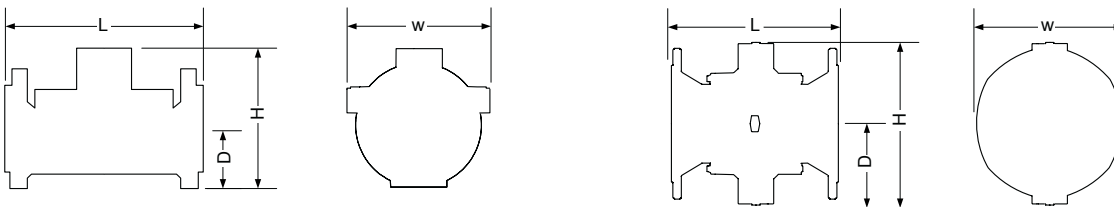

Valve Size		L		H		D		W		Weight	
mm	inch	mm	inch	mm	inch	mm	inch	mm	inch	kg	lbs
50	2	228	8.98	169	6.65	85	3.35	175	6.9	10	22
50TH	2TH	250	8.98	120	6.65	42	1.65	175	6.9	6	13
80	3	310	12.2	237	9.33	105	4.13	200	7.87	30	66.1
100	4	356	14.02	263	10.35	120	4.72	260	10.24	38	83.8
150	6	436	17.17	378	14.88	150	5.91	320	12.6	75	165.3
200	8	530	20.87	481	18.94	180	7.09	400	15.75	123	271

* TH = Threaded

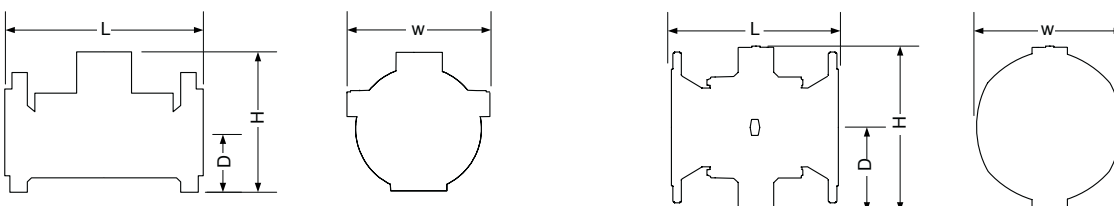

Ultra Gas Loaded Surge Relief Valve

TECHNICAL DATA

HYDRAULIC PERFORMANCE

Valve Size	mm	20	25	40	50	65	80	80LF	100	150	200LF	200	250	300
	inch	3/4	1	1 1/2	2	2 1/2	3 23	3	4	6	868	8	10	12
Max. Flow Continuance	m ³ /hr	6	10	25	40	40	40	100	160	350	350	620	970	1400
	gpm	26.4	44	110	176	176	176	440	700	1540	1540	2730	4268	6160
Max. Flow Intermittent	m ³ /hr	16	27	68	109	109	109	245	273	955	955	1309	2645	3818
	gpm	72	120	300	480	480	480	1080	1200	4200	4200	5760	11640	16800
Minimal Flow	m ³ /hr	< 1												
	gpm	< 5												
Kv	m ³ /hr @ 1 bar	17	17	64	95	95	95	170	220	600	670	800	1250	1900
Cv	gpm @ 1 psi	20	20	75	110	110	110	200	260	700	780	930	1460	2220
Kv*	m ³ /hr @ 1 bar	-	-	-	78	-	-	120	200	550	-	800	1300	-
Cv*	gpm @ 1 psi	-	-	-	91	-	-	140	230	640	-	930	1520	-

* High pressure models

$$\Delta P(\text{Bar}) = \left(\frac{Q[\frac{\text{m}^3}{\text{hr}}]}{Kv} \right)^2 \quad \Delta P(\text{Psi}) = \left(\frac{Q[\text{gpm}]}{Cv} \right)^2$$

HEADLOSS CHART

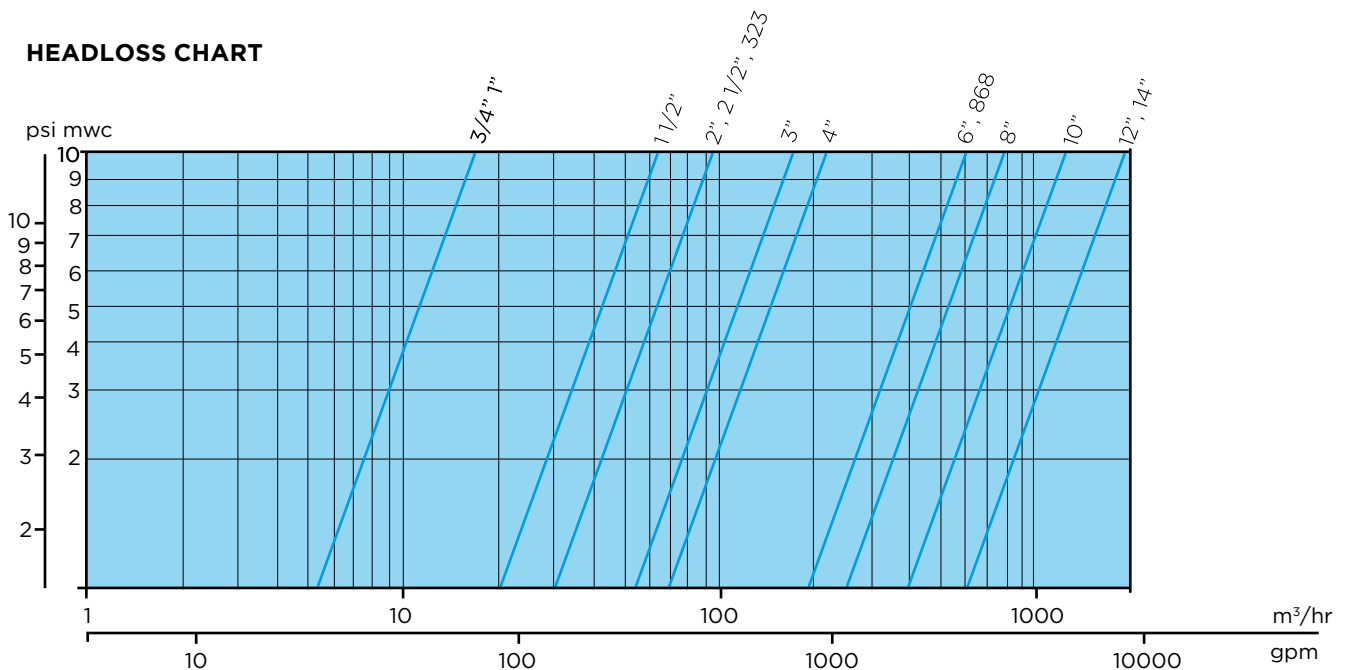

Surge Control Vessels

Ultra Valves have for many years represented a company called H & H from Portugal who specialize in the design and manufacture of Surge Tanks of various configurations.

Bladder Surge Tanks

These are the more popular due to their simplicity and reliability and the fact that the media is stored in a Flexible Butyl rubber Bladder without corrosion issues.

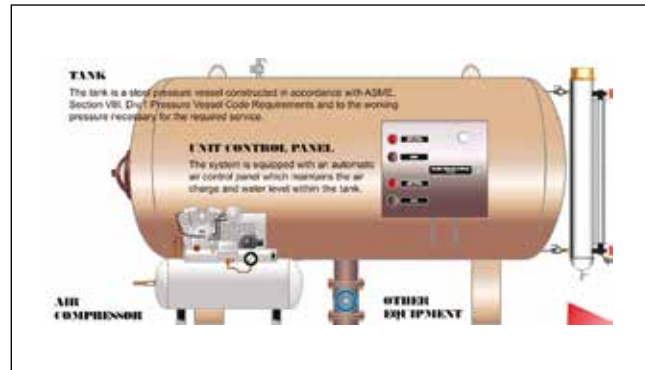

Compressor Vessels

These tanks are charged with Air at the top of the tank. They require a Compressor with all its controls and which can all be supplied with the tank.

Disadvantages is the need for Electricity and associated controls. Air gets absorbed into the water and is required to be extracted in the pipeline.



SURGE TANKS BEING COMMISSIONED IN KZN

Pressure Management

Pressure Management is the science of reducing pressures during low demand periods. It is obvious that the lower a pressure is in a network system, the losses due to leaks will be substantially reduced. The saving can generally be achieved in two different versions and known as "Smart Pressure Reducing valves" in the industry.

- **Time controlled.**

The valve will be set to 2 or 3 different pressures at different times of the day. This is achieved by having different PRV Pilots with different settings on the valve and which get selected by means of a solenoid on the pilot hook-up. The times can be programmed through a custom control panel which is battery operated.

- **Flow controlled**

The valve will respond to changing flow rates i.e., increased pressure settings with increasing flow rates. This system provides the ultimate saving and entails a flow meter and battery-operated controller which responds to changing flow rates.

With this equipment we also have a small generator which works on the differential pressure across the valve and generates enough to power the equipment and do eliminate the need for a Battery
Ultra can assist with Network analysis to decide the best positions for the "Smart PRV's" and what the minimum setpoints can be.

PMV-III PRESSURE MANAGEMENT VALVE

ONE STOP FOR PRESSURE - FLOW - CONTROL



Intelligent
Controller
With Valve

Working 24 x 7

Controller Specification		
Input/Output	Pulse input	Input pulse for flow meter reading
	Analog input	Build in pressure sensor, 0-10 bar or 0-16 bar, Accuracy $\pm 0.5\%$ 2 extra analog 4-20mA input for water level sensor or flow meter. (Customized)
	Output	2 integrated solenoid valves 2 of latch solenoid valves(extra device, not integrated)
Logging	Data Logger	Record 200,000 data (looping record)
	Sampling rate	5-1440 mins based on request
	Alarm	Min / Max - flow / pressure setting
	Clock	Build in RTC
Communication	Communication	4G/3G/GSM/GPRS/EDGE/WCDMA/TD-SCDMA/LTE-FDD/LTE-TDD
	Bluetooth	Using mobile APP to connect to device for inquiry and change setting
Physical	Case	Aluminum
	Working Temperature	-15 ~ 55°C
	Water Proof	IP68
	Electricity	Lithium battery - 5 years under specific working condition

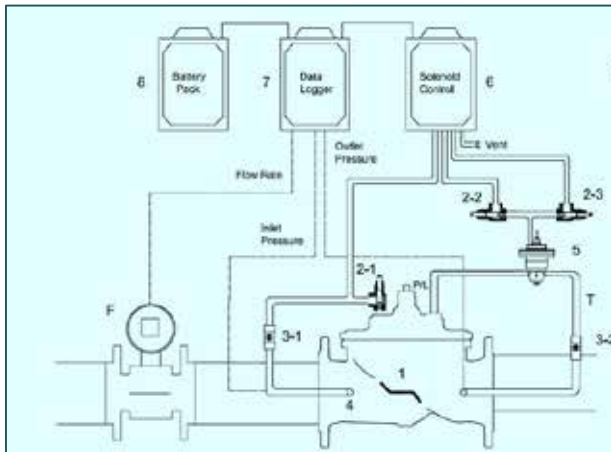

NO.	Part Name	Material
1	Main Valve	GJS 500-7
2	Needle Valve	SUS304
3	Ball Valve	SUS304
4	Strainer	SUS304
5	Hydraulic Control Pilot	SUS304
6	Solenoid Control	Commercial
7	Data Logger	Commercial
8	Battery Pack	Commercial
T	Tube	SUS304



Connectivity Indicators

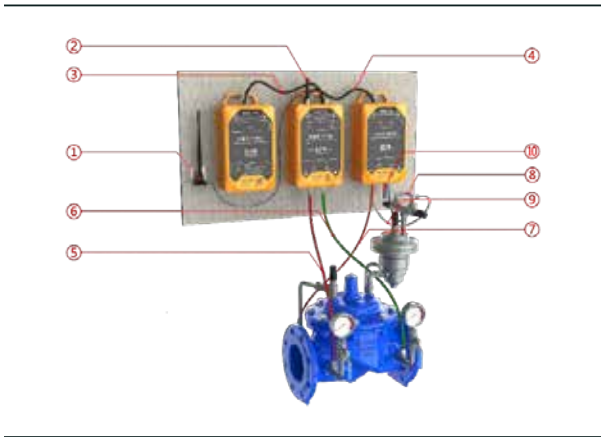

1. LTE antenna with magnet, installed to the ANT. LTE on PMCX.
2. Bluetooth antenna, installed to the ANT. BT on PMCX.
3. 2-core connecting wire, connecting the BAT.BOX1 on PMCX and battery pack CTL. BOX.
4. 8-core connecting wire, connecting the SV.BOX on PMCX and CTL.BOX on PMAX.
5. The red hose with quick coupling is connected to the inlet P. of the PMCX and the plug in of the valve inlet.
6. The green hose with quick coupling is connected to the outlet P. of the PMCX and plug in of the valve outlet.
7. Red hose, connecting sv1 inlet of PMAX and plug in of the valve inlet.
8. Blue hose, connecting sv1 outlet of PMAX and pilot valve (with blue mark).
9. White hose connecting SV2 inlet of PMAX and pilot valve.
10. Black hose is installed to SV2 outlet of PMAX; (other color hose can be used for water outlet).

Power Options



Lithium Battery

1. Easy Installation.
2. 12 hrs. uploading data can last 5 years life.

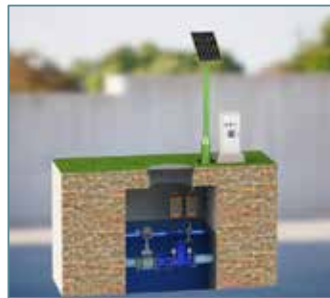

Solar Panel

1. Need 12V input
2. No limit for data uploading period



Hydraulic Power Generator

1. Easy Installation
2. Start to generate enough power when delta > 0.5 bar
3. No limit for data uploading period

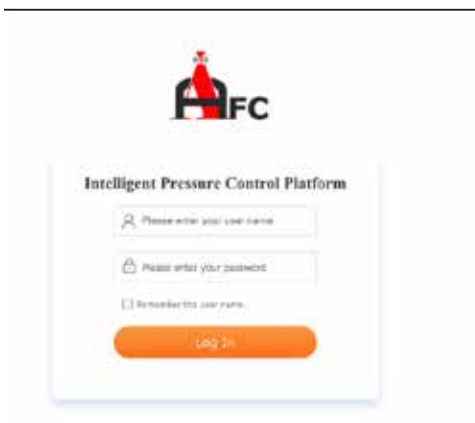

Login Interface

Easy to Login by Using Mobile Phone Or PC

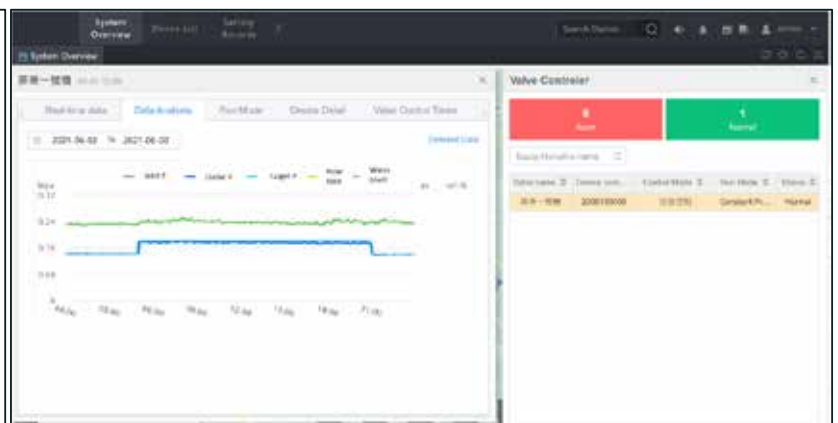

Device History Data

Export to Excel Format Easy to Check the Target and Real Data to Understand How the Device Works.

USER FRIENDLY INTERPHASE

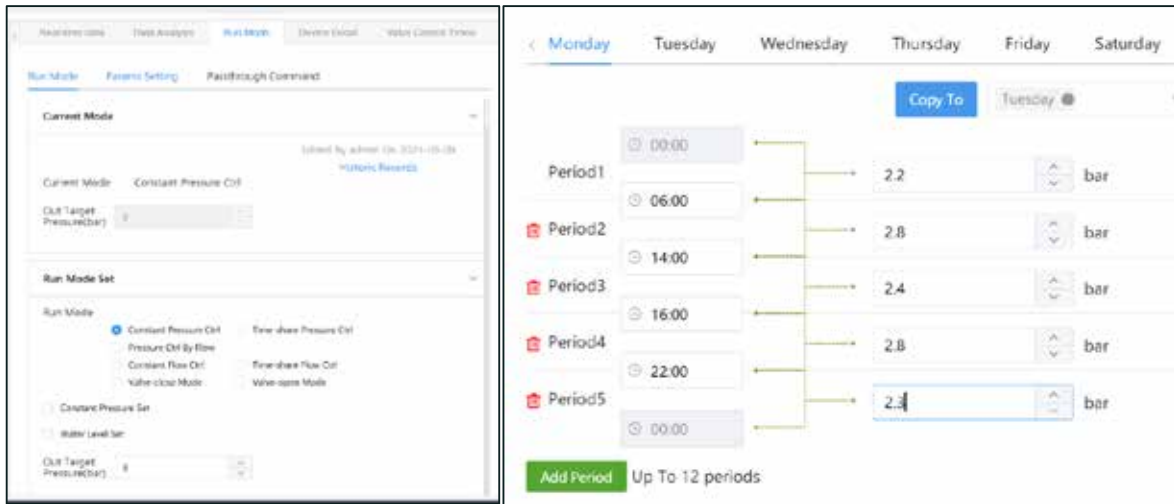

Control Modes

- Pressure Control
- Flow Control
- On/Off
- Level Control

Settings

- Time VS P
- Flow VS P
- Time VS Flow
- Additional Integrations



The Ultimate Valve that uses hydraulic energy to generate electricity. The Valve generates enough power when $\Delta P > 0.5$ bar. Another advantage is -No limit for data uploading. Ask us more for PMV-III (Hydro).

Valve Cover Chamber Capacity

The chamber between cover and diaphragm is capable of holding the following volume of liquid. This chamber discharges liquid to open valve and must be filled to close valve. If your application requires the

valve to discharge to atmosphere this information will be helpful to size drains or discharges lines. These volumes can also be used to calculate time of closure (or opening).

Size Full Bore	DN50	DN65	DN80	DN100	DN150	DN200	DN250	DN300	DN400	DN500	DN600	DN700	DN800
Size Reduced Bore	DN80		DN100	DN125/ DN150	DN200	DN250	DN300	DN350/ DN400			DN700/ DN800		DN1000
Volume (mm ³)	188475	294554	481749	978163	2808024	6202552	10974635	17542711	25260452	47404894	81876620	159404096	244862930
Litres	0,19	0,29	0,48	0,98	2,81	6,2	10,97	17,54	25,26	47,4	81,88	159,4	244,86

Cavitation Chart

After selecting valve size, locate inlet and outlet pressures on this chart. If the intersection point falls in the shaded area, cavitation can occur. Operation of valves continually in the cavitation zone should be avoided.

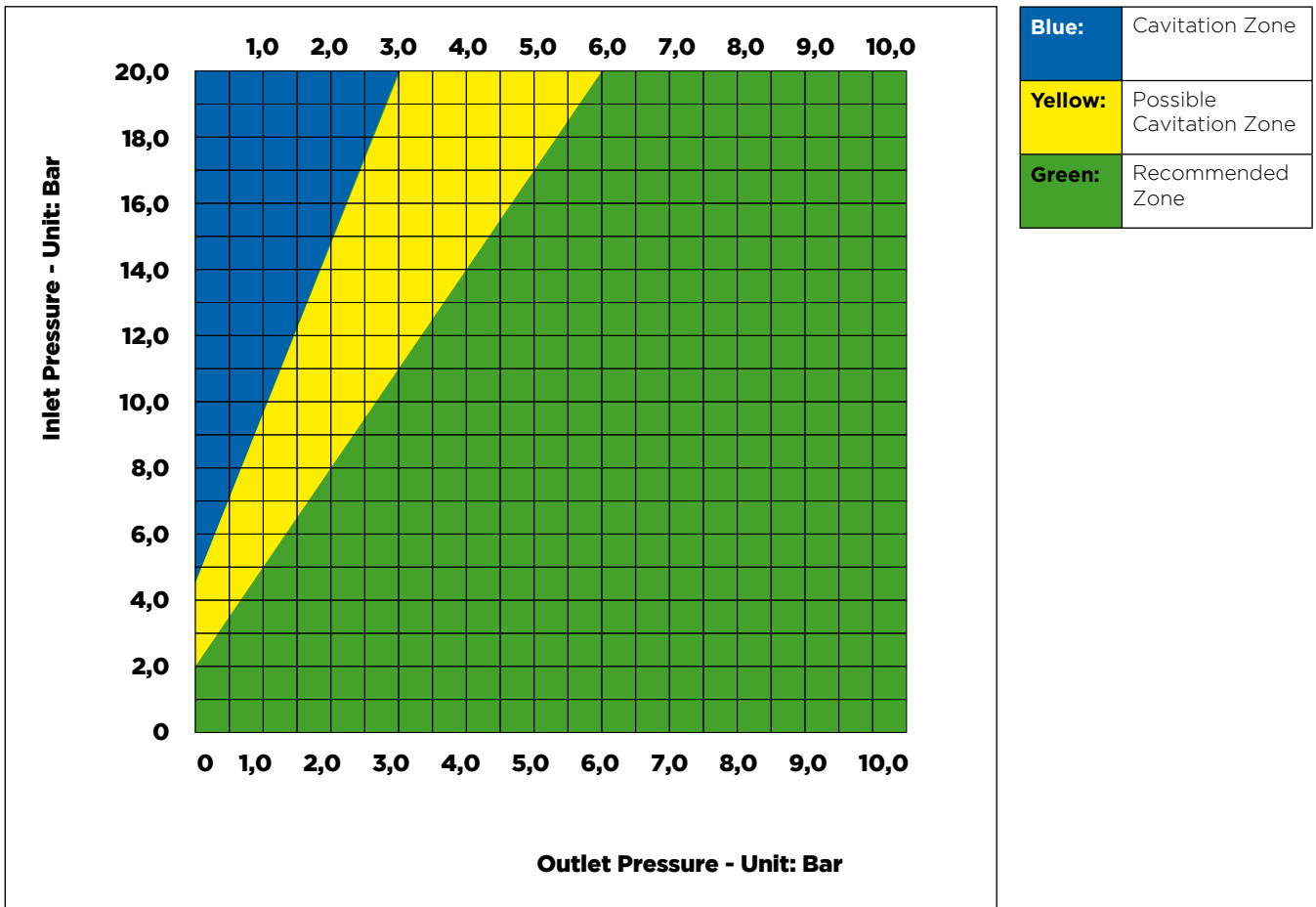

Ultra-Alpine Sizing

VALVE SIZE FULL BORE	50	65	80	100	150	200	250	300	400	450	500	600	700	800
Max. recommended Continuous Flow m ³ /hr	47	72	109	180	410	720	1116	1584	2715	3440	4243	6110	8316	10862
Max. Intermittent Flow m ³ /hr	61	90	130	227	522	900	1368	1962	3186	4320	5400	7956	10800	13680
Min. stable flow rate	4	6	8	13	25	47	68	90	148	227	281	407	554	724
VALVE SIZE REDUCED BORE	80		100	125/150	200	250	300	350/400	450			700/800		1000
Max. recommended Continuous Flow m ³ /hr	47		109	180	410	720	1116	1584	2715			6110		10862
Max. Intermittent Flow m ³ /hr	61		130	227	522	900	1368	1962	3186			7956		13680
Min. stable flow rate	4		8	13	25	47	68	90	148			407		724

VALVE SIZE FULL BORE	50	65	80	100	150	200	250	300	400	450	500	600	700	800
Max. recommended Continuous Flow m ³ /hr	13	20	30	50	114	200	310	440	754	955	1179	1697	2310	3017
Max. Intermittent Flow m ³ /hr	17	25	36	63	145	250	380	545	885	1200	1500	2210	3000	3800
Min. stable flow rate	1	1.5	2	3.2	7	13	19	25	41	63	78	113	154	201
VALVE SIZE REDUCED BORE	80		100	125/150	200	250	300	350/400	450			700/800		1000
Max. recommended Continuous Flow m ³ /hr	13		30	50	114	200	310	440	754			1697		3017
Max. Intermittent Flow m ³ /hr	17		36	63	145	250	380	545	885			2210		3800
Min. stable flow rate	1		2	3.2	7	13	19	25	41			113		201

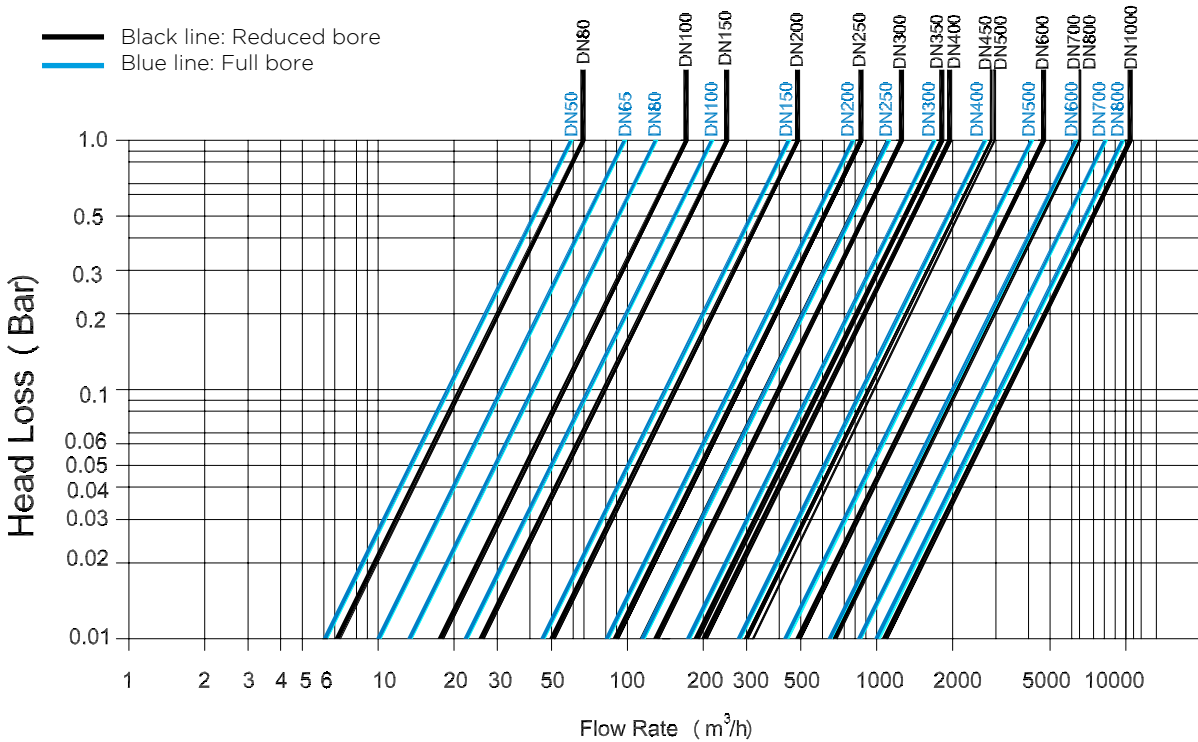

KV Values

	DN50	DN65	DN80	DN100	DN150	DN200	DN250	DN300	DN350	DN400	DN450	DN500	DN600	DN700	DN800	DM1000
A900	60	99	139	224	451	798	1225	1785		2700		4500	6000	7500	8900	
R900			72	162	258	487	830	1286	1838	1927	2808	2916	4815	6100	6100	10235

Kv Values can be used in the following equations to calculate Q (Flows in m³/hr) and ΔP (Pressure drop in bar)

$$Q = Kv \sqrt{\Delta P} \quad \Delta P = (Q/Cv)^2$$

$$Kv = \frac{Q}{\sqrt{\Delta P}}$$



Address: 272 Bath Street Glasgow G2 4JR Cell: +44 (0) 776348 8809: Land: +44 (0) 1369 760423:
Email: john@afcvalves.co.uk: Web: www.afcvalves.co.uk