

SKAS-Sewage Combination Air Release Valve

Features:

- . Advanced design with simple mechanism, strong float to prevent cracking during sudden water hammer & quick closure.
- . Aerokinetic mechanism to resist blow shut under higher air velocity even up to sonic velocity of air.
- . With special fat body design to lower the sewage water flow speed, and let the air out but keep sewage water underneath.
- . Keep dirty or corrosive liquid inside the body for safety during operation and no harm to human & surrounding environment
- . Internal body guide and upper round wall keep float moving on its rail and keep liquid turbulence flow within this area.
- . Much bigger air flow through the nozzle even for higher viscosity liquid.
- . Outside screen will be an option for safety and prevent insects or birds in.
- . Fully fusion epoxy coated inside and outside of valve body for long term services.
 - . Flange meets BS EN 1092 and ANSI flange.

SKAS- Sewage combination air release valve Provides 3 functions:

- 1.Large air release during filling of the pipeline.
- 2.Small air venting under pressurized pipeline.
- 3.Large air intake during draining of the pipeline.



Service Fields:

For sewage water system.

Technical Data:

Size range: DN 50MM
Pressure ratings: 1.0Mpa, 1.6Mp (Thread)
Working temperature: -10°-80°C.
Flow media: sewage water.

Main Valve-DN50

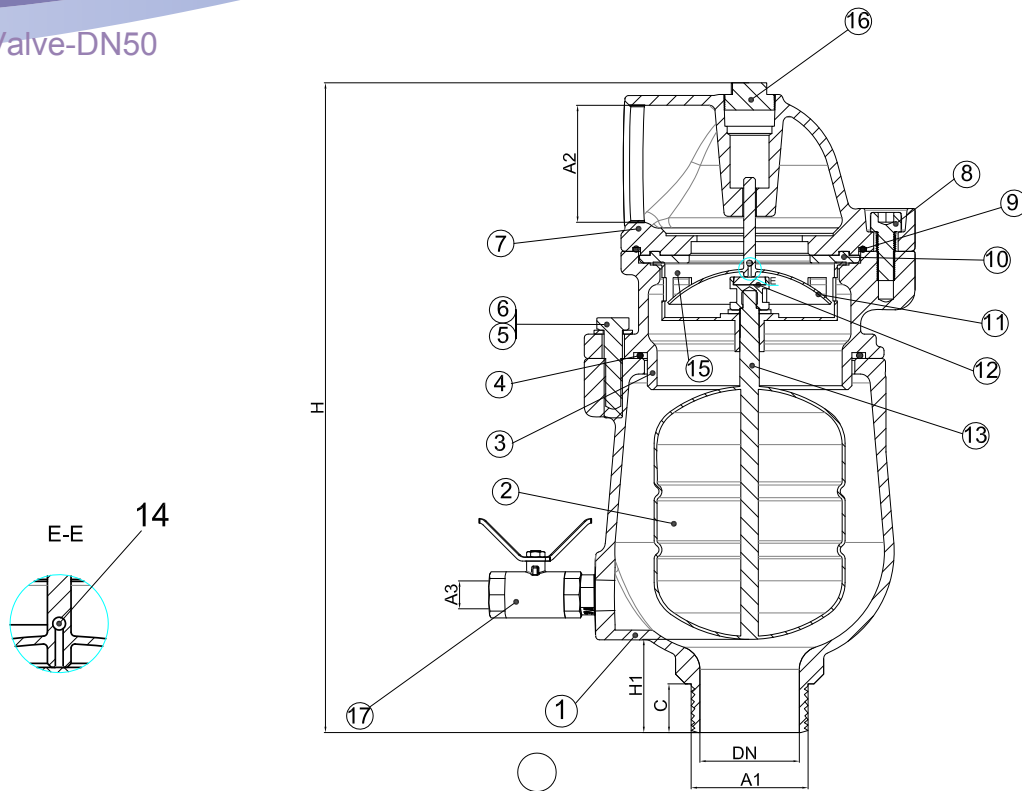

Parts List

No.	Part Name	Material	Standard
1	Body	Ductile Iron	EN GJS 500-7
2	Float	Stainless Steel	AISI 316
3	Middle Part	Ductile Iron	EN GJS 500-7
4	O-Ring	Rubber	NBR
5	Hex Bolt	Stainless Steel	AISI 316
6	Washer	Stainless Steel	AISI 316
7	Bonnet	Ductile Iron	EN GJS 500-7
8	Screw	Ductile Iron	EN GJS 500-7
9	O-Ring	Rubber	NBR
10	Seat	Rubber	NBR
11	Sealing Arc	Stainless Steel	AISI 316
12	Nozzle Seat	Rubber	NBR
13	Stem	Stainless Steel	AISI 316
14	Small Nozzle	Stainless Steel	AISI 316
15	Guide Barrel	Stainless Steel	AISI 316
16	Plug	Stainless Steel	AISI 316
17	Butterfly ball valve	Stainless Steel	AISI 316

Dimension

Unit: MM

Dimension						
DN	A1	A2	A3	C	H1	H
50	G2"	G2"	BSPT3/8"	25	48	333.5

BIG NOZZLE EXHAUSTING / INTAKE

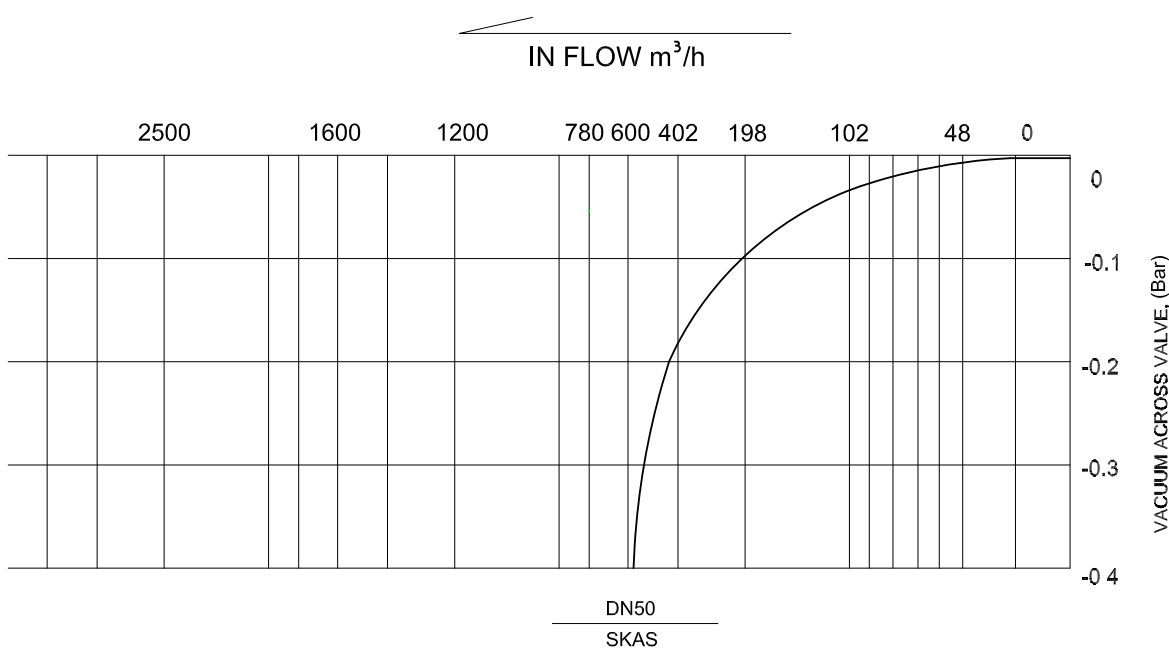
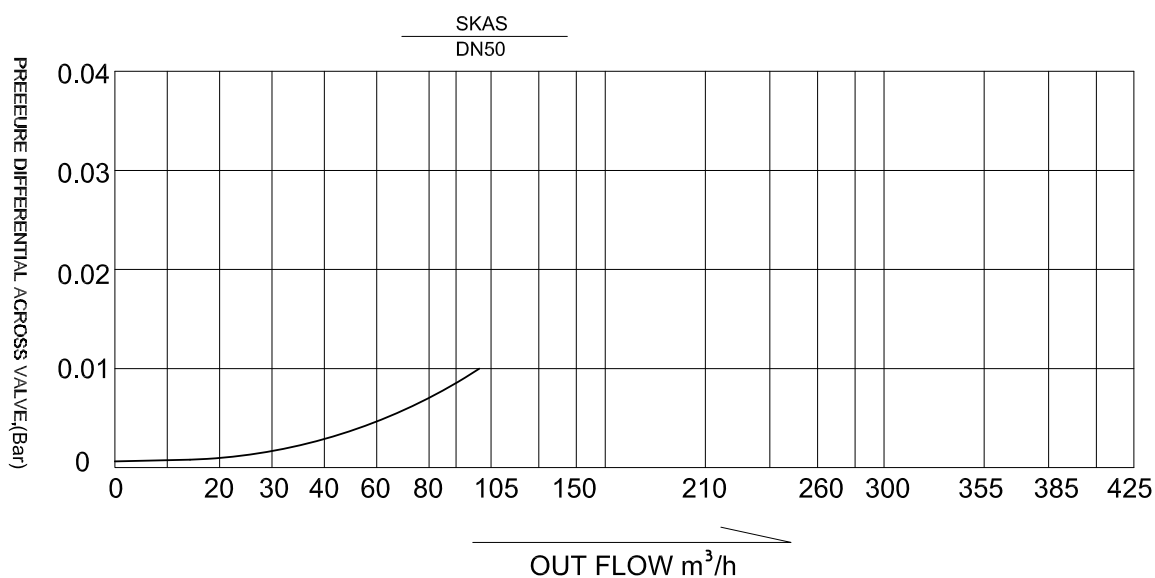

* AFC keeps the right to change dimension without further notice.



SMALL ORIFICE VENTING

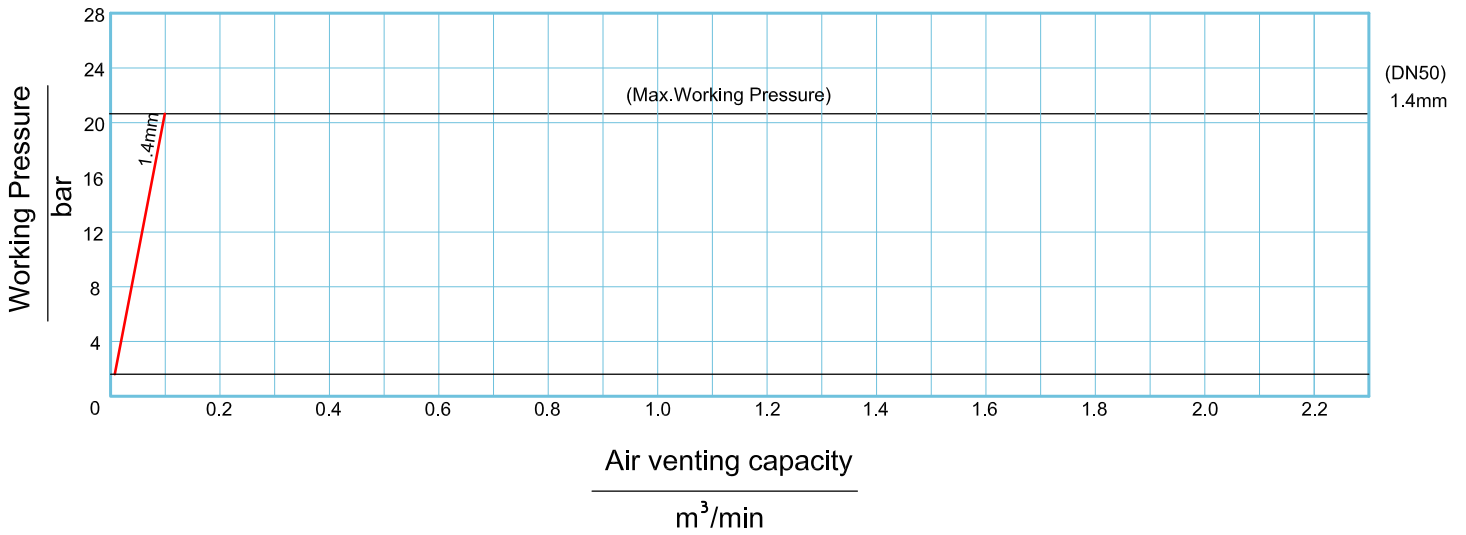

Ordering Code

Model:
SKAS- Sewage combination air valve

